

SMALL LIVING, COLLECTIVELY

Integrating Micro-Housing Communities into Portland Neighborhoods

SMALL LIVING, COLLECTIVELY

Integrating Micro-Housing Communities into Portland Neighborhoods

by
Adam McSorley

Thesis document submitted in partial fulfillment of the
requirements for the degree of Master of Architecture

at

Portland State University
Portland, Oregon
June 2016

**PORTLAND STATE UNIVERSITY
SCHOOL OF ARCHITECTURE
COLLEGE OF THE ARTS**

The undersigned hereby certify that the Masters thesis of

Adam McSorley

has been approved as partial fulfillment of the requirements for
the degree of Master of Architecture

Thesis Committee:

Advisor

Sergio Palleroni
Professor, Director of
Center for Public Interest Design

Date

Committee Member

Barbara Sestak
Professor

Date

Acknowledgements

To my family for the encouragement and patience.

To Sergio for all the great ideas.

To the faculty of the School of Architecture at Portland State University for the constant support and guidance

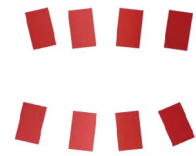

Abstract

Recently, there has been a large social and economic change happening within many American cities caused in large part by the convergence of the two most substantial demographics – the Baby Boomers and Millennials. As these groups continue to move into urban settings, the price of housing increases to a point the existing population cannot sustain, oftentimes leaving them no choice but to move from their desired neighborhood or even outside of the urban boundary. Furthermore, when studying the current housing landscape within the city of Portland, Oregon, the most common prevalent development models found within urban neighborhoods is to demolish smaller, older existing homes and replace them with larger new constructions which maximize square footage within a given lot in order to maximize profit.

A new and alternate form of housing must be presented which provides affordable living while positively impacting the overall community in which it is built as well as mitigating the substantial demographic shifts taking place in order to combat gentrification and displacement. In this study, the neighborhoods of Portland, OR are used as a case study for integrating well-designed micro-communities which fit into the fabric of the city as an economically and socially viable alternative to the current housing trends. This proposed typology will present the opportunity for population growth without denying the right of existing residents to the city, and will provide a sustainable economic solution for the lower and middle classes.

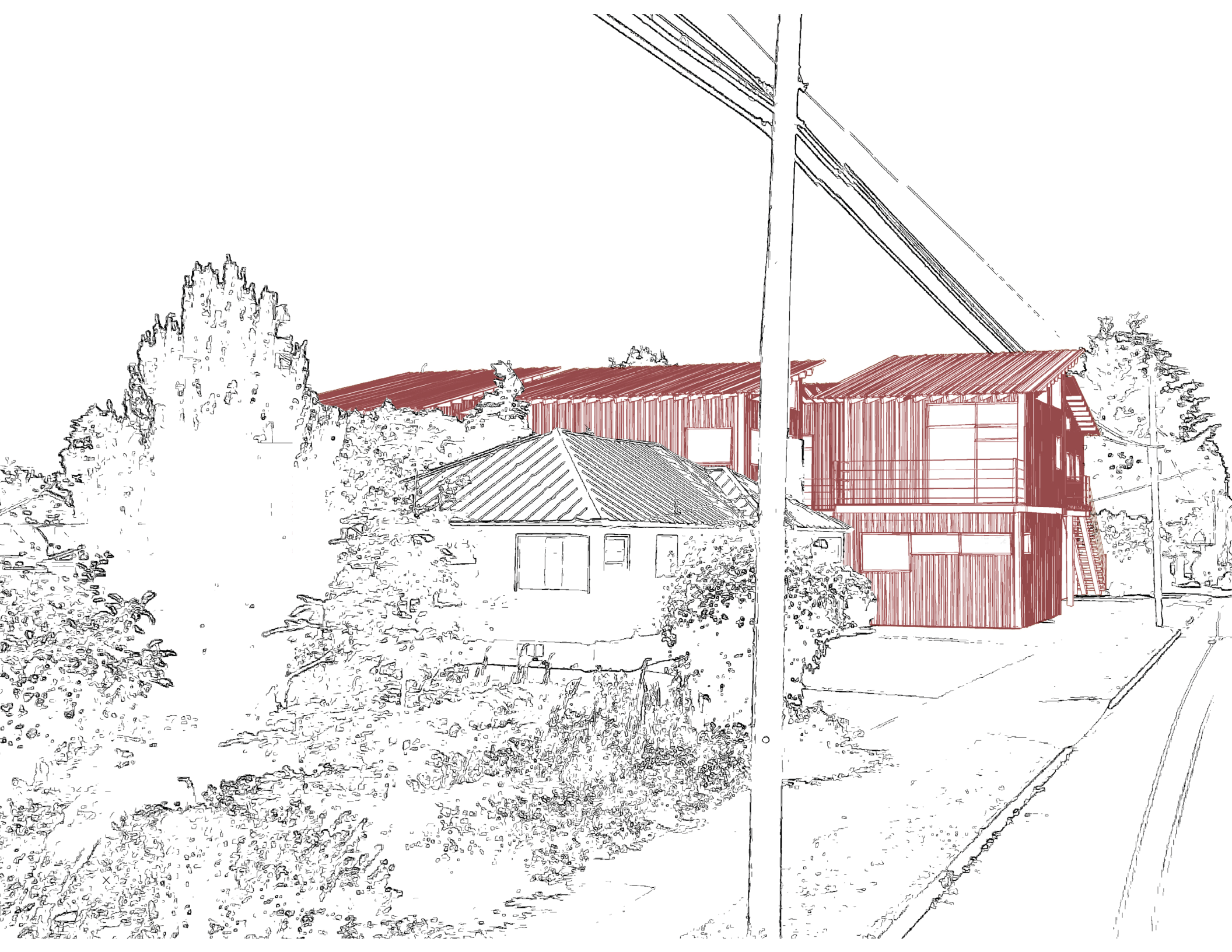

Research Question

In American cities, such as Portland, Oregon with increased population growth causing historically low vacancy rates and high housing costs that are out of the reach of the lower and middle classes, how can well designed micro-communities be integrated into the economic and social sustainability of the larger urban neighborhood fabric?

Table of Contents

Preface	xiv	Design Exploration.....	49
The Current State of Housing in Portland.....	1	Site Layout	
A Shift in Housing		Unit Design and Function	
Housing Landscape in Portland		Community Space	
Recent Housing Statistics		Resident Profiles	
Development Models and Typologies	15	Conclusions	67
Strategies of Development		Next Steps Toward Integrating Micro-Housing Communities	
Existing Alternative Models in Portland		Development Update of Proposed Sites	
Models and Roles of Developers		Appendix A: List of Figures	
Micro-Housing Typologies		Appendix B: Bibliography	
Neighborhood Analysis	31		
Finding the Ideal Site			
Demographics			
Site Possibilities			
Initial Design Investigations			
An Alternative System	39		
Micro-Housing Form			
Community Connections			
Financial Feasibility			

Preface

While the statistics and demographics shown in the following sections clearly show how residents within the city of Portland are being affected by the current changing housing landscape, it becomes much more poignant when you hear direct individual tales of displacement and seeking out new homes. As it just so happens, after I had already begun researching the topic of current Portland housing trends affecting low income residents, my family and I were given notice of yet another rent increase to our home in which we had lived in for the past five years. This latest increase would bring the rent up to a price 60% higher than what we were originally paying, and would make remaining in that location no longer viable for our four person, low income household. As we begin to look for a new home it became very clear what the statistics I had been studying meant on a much more personal, spatial, financial, and emotional level. **Five key points began to**

emerge as my family searched for a new home.

After accepting these conditions, we were eventually able to find a new home; a courtyard apartment about a mile and a half south of our current location. While we lucky enough to find a new home within our price range and only about a mile and a half from our previous home, we did have to sacrifice much of the amenities offered in our old neighborhood and home which we had grown to love over the past five years.



1

Three bedroom homes were not an option in our search area

With vacancy rates of 0% for three bedrooms, not only was it rare to find one, when you did the rent was far out of our price range. Even two bedrooms with a 2.3% vacancy rate were rare, but at least they were more affordable.

2

We would have to give up a substantial amount of square footage

Rising costs throughout the city made any home within the square footage range we were used to out of our new price range.

3

Single family dwellings were unaffordable

Just as three bedrooms were hard to come by and out of our price range, so too were detached single family homes.

4

Duplexes and apartments were scarce and off the market quickly

Even if multifamily properties became available they were often rented within a few days, especially within our current neighborhood.

5

We would have to move out of our neighborhood and school district

As all of the above factors became more burdensome, we realized not only would we need to leave our neighborhood which we had lived in for the past five years, but we would need to move outside of the school district as well, causing our two children change schools.



FROM



To



**2 Bedroom / 1 Bath
700sf Courtyard Apartment
Small Shared Yard
Mount Scott Neighborhood (Outside of Former
School District)**

Figure 0.1 - Relocation Diagram



Meanwhile, as rental costs became more and more unaffordable within our neighborhood, I began to notice the changing form of housing. On nearly every street within the neighborhood, older and smaller homes were being torn down and replaced by larger homes which would maximize the square footage allowed within the lot in order to maximize the profit when selling or renting these new homes. In theory, it would stand to reason that these larger homes would begin to house more people; however, the average neighborhood occupancy remained stagnant at about 2.4 people per unit within the neighborhood throughout the past 5 years. Anecdotally, I perceived a disturbingly low density within these new houses as I watched one particular house with about 3000 square feet of space on our street go through two owners throughout our time in the neighborhood. The first residents were a young couple, and the second, current, resident is a single, young working professional. It never made sense to me why a single resident needed over three times the space as my family of four comfortably living in our small 100 year old home. Watching this shift in housing forms presented me with two questions. First, would this young couple or single person resident have purchased a smaller home if given the option, and second, if they had purchased a smaller



Figure 0.2 - Before and After Comparison of Homes within the Foster Powell Neighborhood

existing home, would the inherent lower sale prices of smaller spaces maintain both rental and purchase prices throughout the neighborhood at more affordable levels for the existing residents, like myself and my family? Of course, these perceptions and questions I was having within my own situation came full circle to the question I was already pursuing within the research of this thesis. Could a new form of development replace this existing structure and begin to introduce an alternative development model and housing type to curb the displacement of lower income residents, or perhaps even just present a more logical living space for the influx of Millennials and Baby Boomers into Portland neighborhoods?



The Current State of Housing in Portland

A Shift in Housing

In recent years, there has been a significant shift in residential housing - both ownership and rental - within urban boundaries throughout many large cities within the United States which has resulted in extremely low vacancy rates and sky rocketing housing prices. Often, this shift is attributed in large part to the desires of the two largest demographics – the baby boomers and the millennials - to reside within metropolitan areas. Decades ago, large numbers of the baby boomer generation left the urban environment in favor of sprawling suburbs which offered what they felt was an improved environment for raising a family. Now, as most of their children have grown and left the home, a large number of these boomers are ready to reintegrate into the city and take advantage of the amenities it provides which the suburbs do not. Additionally, there are those who never fled to the suburbs and as they are growing older have decided to age in place rather than move outside of the city or live in assisted living homes; therefore, prolonging the recycling of their housing stock back into the market. Whether they are migrating back to the city or simply choosing to stay in their urban abodes through the remainder of their lives, it is clear this vast slice of the population, unlike generations before them, would like to take advantage of the benefits of the city such as walkability, convenient public transit, and cultural events. While the Baby Boomer generation is immensely substantial, consisting of about 78 million Americans, it only ranks second to the Millennials who are now made up of around 95 million young adults, a large number of which, just like the Baby Boomers, are seeking the comfort of walkability and city amenities. As many of these Millennials progress through adulthood as young working professionals, they are not fleeing to the suburbs to raise children as their grandparents did, but rather they are choosing an urban lifestyle and forming non-traditional families. These changing notions of where these two large demographics are deciding to live has caused tremendous impact on the housing stock and prices throughout metropolitan areas within the United States, and recent research and statistics have shown that the city of Portland is no exception to this phenomena.

Housing Landscape in Portland

With increasing population density and a desire to live within and near the urban core by the two largest demographics in America, the landscape of the housing and rental market within Portland is changing at a rapid rate. The residential developer's response has mainly been to pursue two options of new housing construction. First, there has been a recent construction boom of mid to high end apartment buildings which are typically located near the downtown area and are often out of the price range of many low and mid income families and individuals. Even when developers do make use of incentives by the city to include affordable housing units within these buildings, these are usually unattainable to anyone below an 80% area median income (AMI) level; however, this building type in general does positively affect the overall density levels of the city and provides the most logical housing models to accommodate the shifting demographics. Second, and more important to the questions explored within this thesis, is the changing landscape of the neighborhoods within the city by construction of large single family homes where smaller homes once existed. Regardless that a large percentage of these new Millennial and Baby Boomer residents seeking housing within the urban environment no longer fit the typical family model seen in past generations, new developments within neighborhoods continue to follow the single family home form which has transformed in the last 40 years from an average of about 1600 square feet in the 1970s to about 2600 square feet in 2015. Paradoxically, while homes have trended toward larger square footages over the past four decades, the average household size has decreased from around 3 down to about 2.5 people. While it may be difficult to pinpoint exactly why the trend of ever increasing square footage continues regardless of decreasing family size, it is clear that a new family typology is emerging which could undoubtedly benefit from alternative housing choices within the urban neighborhoods surrounding cities such as Portland.

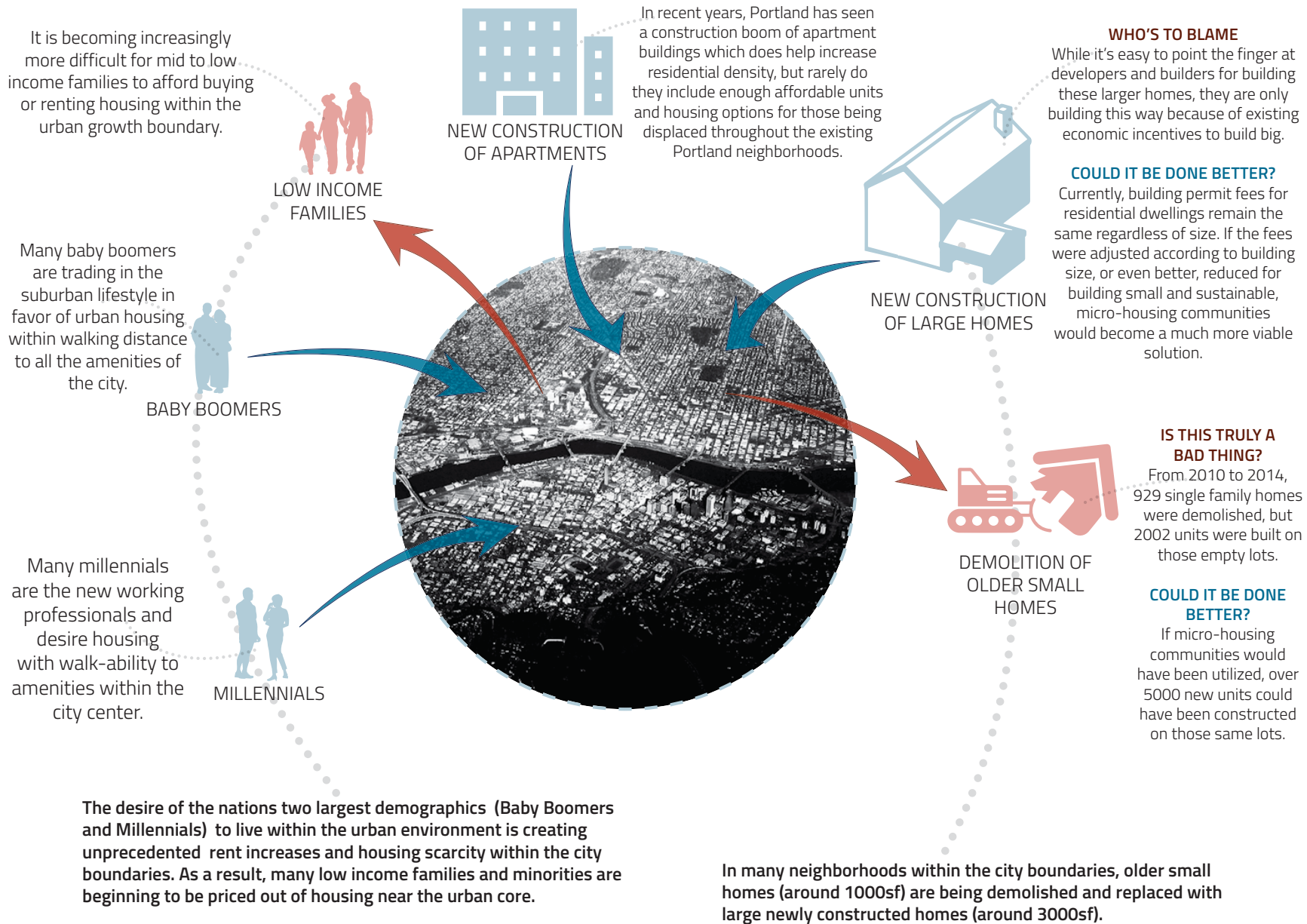

Figure 1.1 - Diagram of Portland Housing Landscape

Recent Housing Statistics

Recent housing data for the Portland area clearly shows how the rental and real estate markets are changing rapidly due in large part to the large demographic shift taking place not only in this area but throughout the United States. Therefore, it is not only important to look at how recent statistics are affecting residents of Portland, but also realistically comparing this local housing market against other large cities to gain an understanding of how the situation can only become worse without intensive reform to the traditional system of development. There is a wide array of detailed statistical information which can show the changing housing environments within the city of Portland or U.S. cities as a whole; however, the following graphics display a succinct range of information pertinent to telling the story of the current housing landscape and providing a lead-in to the discussion topic of the integration of micro-housing communities as an alternative model to the character of existing residential development within an urban area.

Population Growth vs. Housing Growth

Portland, OR (2005 - 2015)

- The city of Portland has shown tremendous population growth throughout the past decade and is predicted to only increase more rapidly throughout the next 20 to 30 years.
- However, as shown here the percentage of growth of housing stock has failed to keep up with the inflow of residents to city.
- Obviously, it is impossible to predict exactly how long this gap between population and housing growth will continue and if it will increase or narrow, but the current gap provides a good indication of why costs housing costs have risen to where they are and why the rental vacancy rate steadily plummets throughout the area as a whole.

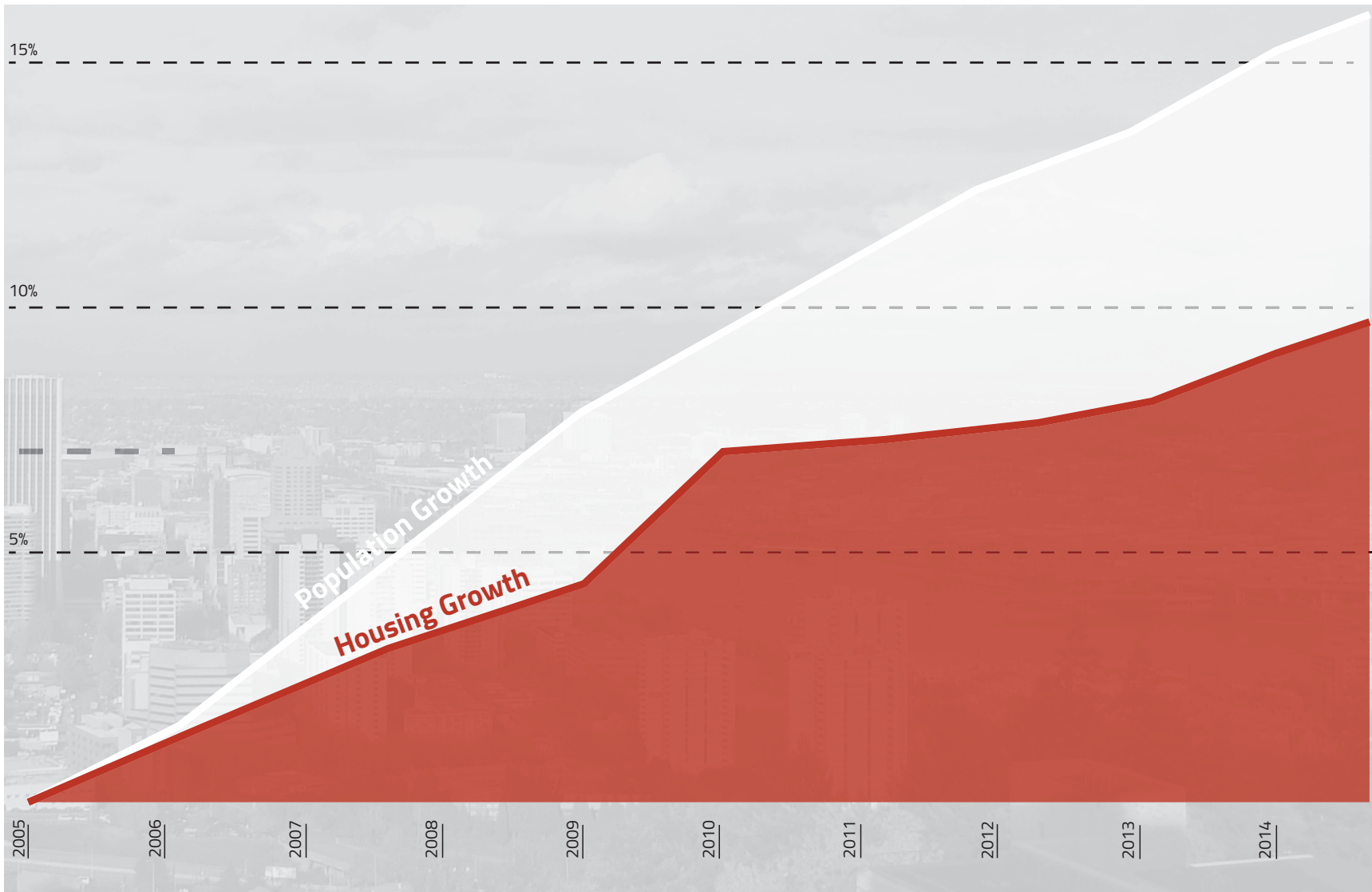

Data Source: U.S. Census Bureau
 Housing Growth Based on New Units Permitted in Portland

Figure 1.2 - Population Growth vs. Housing Growth Chart

Housing Affordability

Portland, OR (2015)

A recent report published by the Portland Housing Bureau looks at the overall affordability of houses within the area and begins to paint a picture of how the median annual income of a household can very much dictate the location of residency. Furthermore, from a statistical point of view, nearly all of the city has become unaffordable to low income families whether seeking to rent or own a home in neighborhoods within the urban area. This type of information begins to show the possibilities of many low income people being displaced from homes within neighborhoods which were once affordable, but now through market forces of supply and demand have become a non-viable housing option.

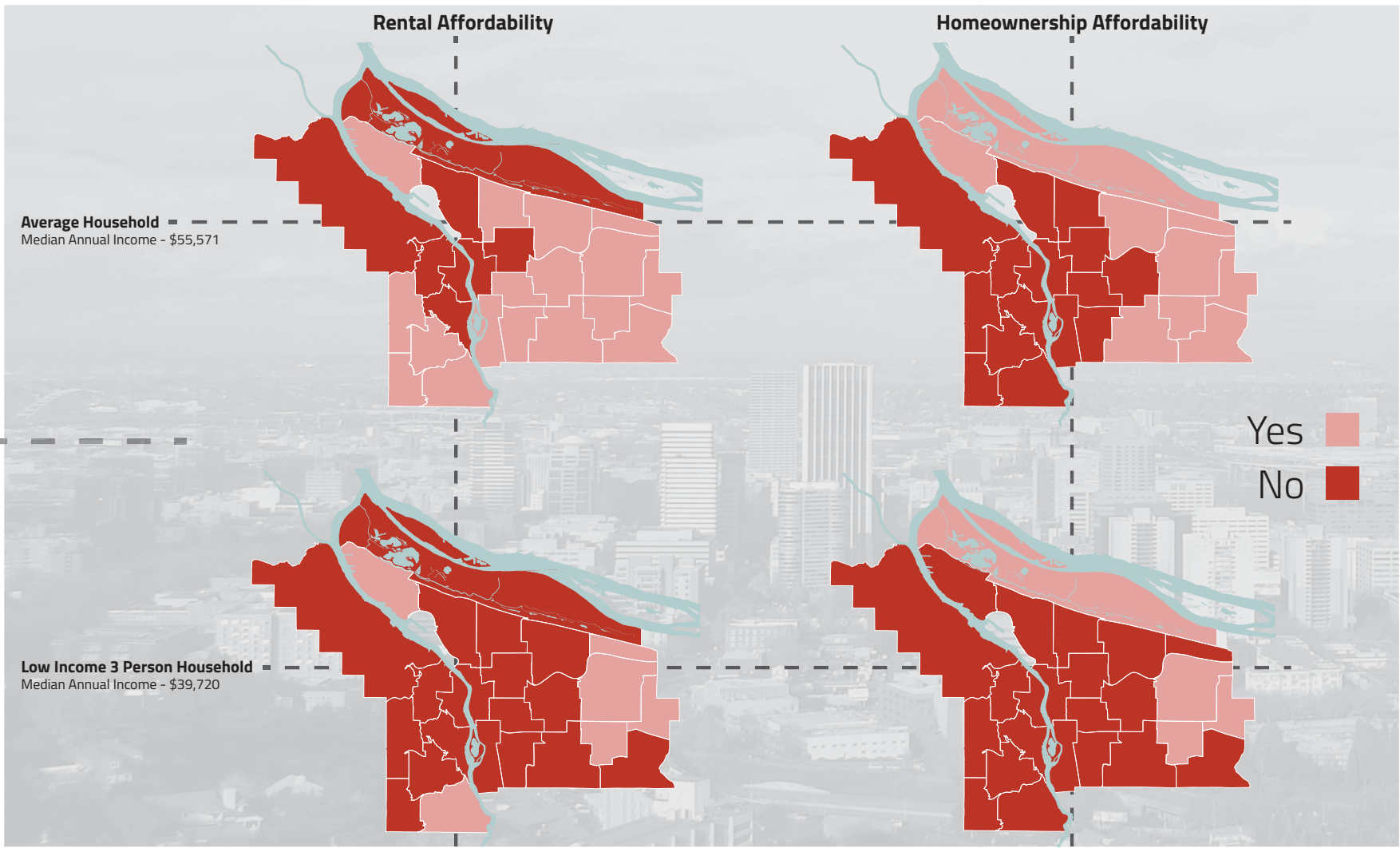

Map and Data Source: Portland Housing Bureau 2015 State of Housing Report
 Affordability determined by less than 30% of the median household income spent on housing.

Figure 1.3 - Housing Affordability Chart

Salary Needed to Buy Home

Top U.S. Cities (2015)

At first glance this comparison of the salary needed to buy a home within some of the largest cities throughout the United States seems to be a positive factor when considering housing affordability in Portland; however, the important information to take away from this data is that Portland can easily be seen as an alternative place to live for residents of the nine large cities which are more expensive - especially the four west coast metropolises. As these residents begin to migrate more and more to Portland because of the relative affordability it offers, this additional population growth will undoubtedly exasperate the current housing crisis causing further displacement of current residents within the city.

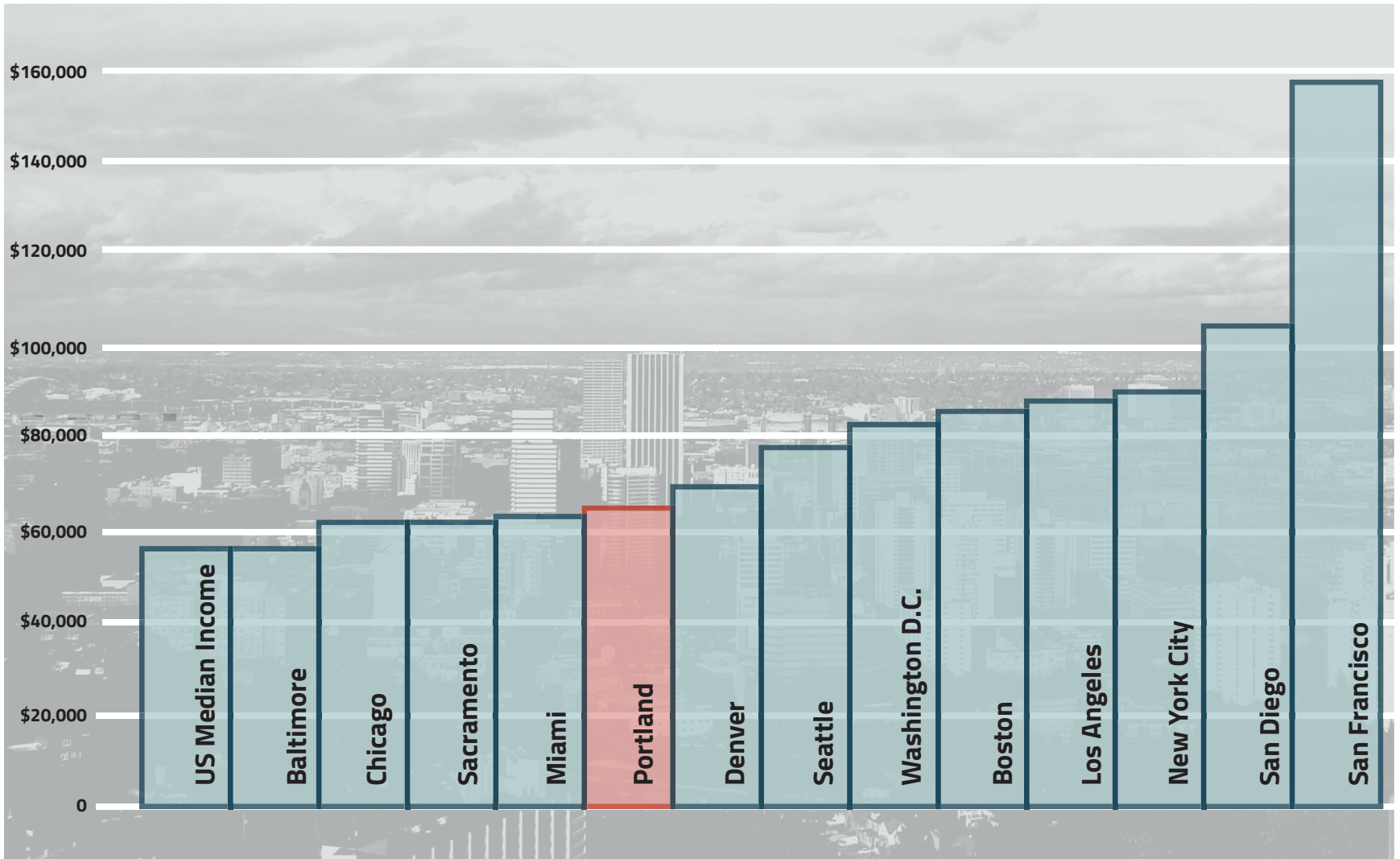

Data Source: *hsh.com* and *sentierresearch.com*
Based on Median Home Price

Figure 1.4 - Housing Income Affordability Chart

■ **Rental Unit Vacancy Rate Comparison**
(2005-2015)

■ It is clear from recent data that the Portland rental housing market is much more competitive compared to the national average throughout U.S. cities. Overall the rental vacancy rate within Portland has been on a steady decline since 2005, and in the past two years has reached an unprecedented new low falling below the 3% threshold. Not only does the low vacancy rate affect the availability of places to live, it causes rental prices of what is available to be much higher than normal, and makes it difficult for people with low incomes and/or less than perfect credit histories to be approved.

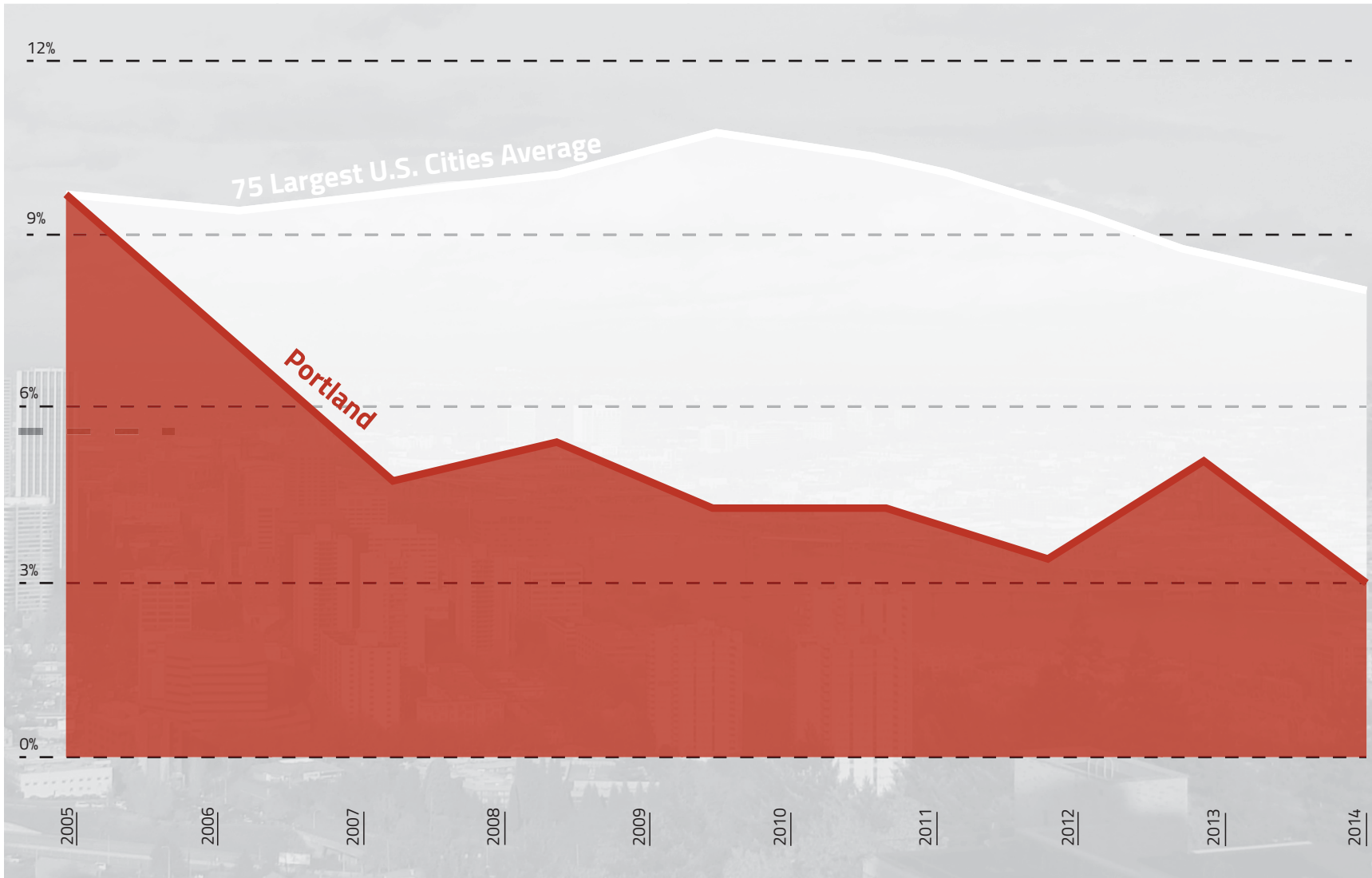

Data Source: U.S. Census

Figure 1.5 - Rental Vacancy Rate Comparison Chart

Residential Demolition Permits Issued

Portland, OR (2015)

With 323 residential demolition permits issued in 2015 alone, it is apparent that the housing landscape within Portland is rapidly changing. While it is debatable as to whether taking out existing housing stock and replacing it with new housing stock has a positive or negative impact on issues such as density and sustainability, it is clear from previously shown statistics that this method is not providing a solution to the increasing affordability issues and low vacancy rates seen throughout Portland.

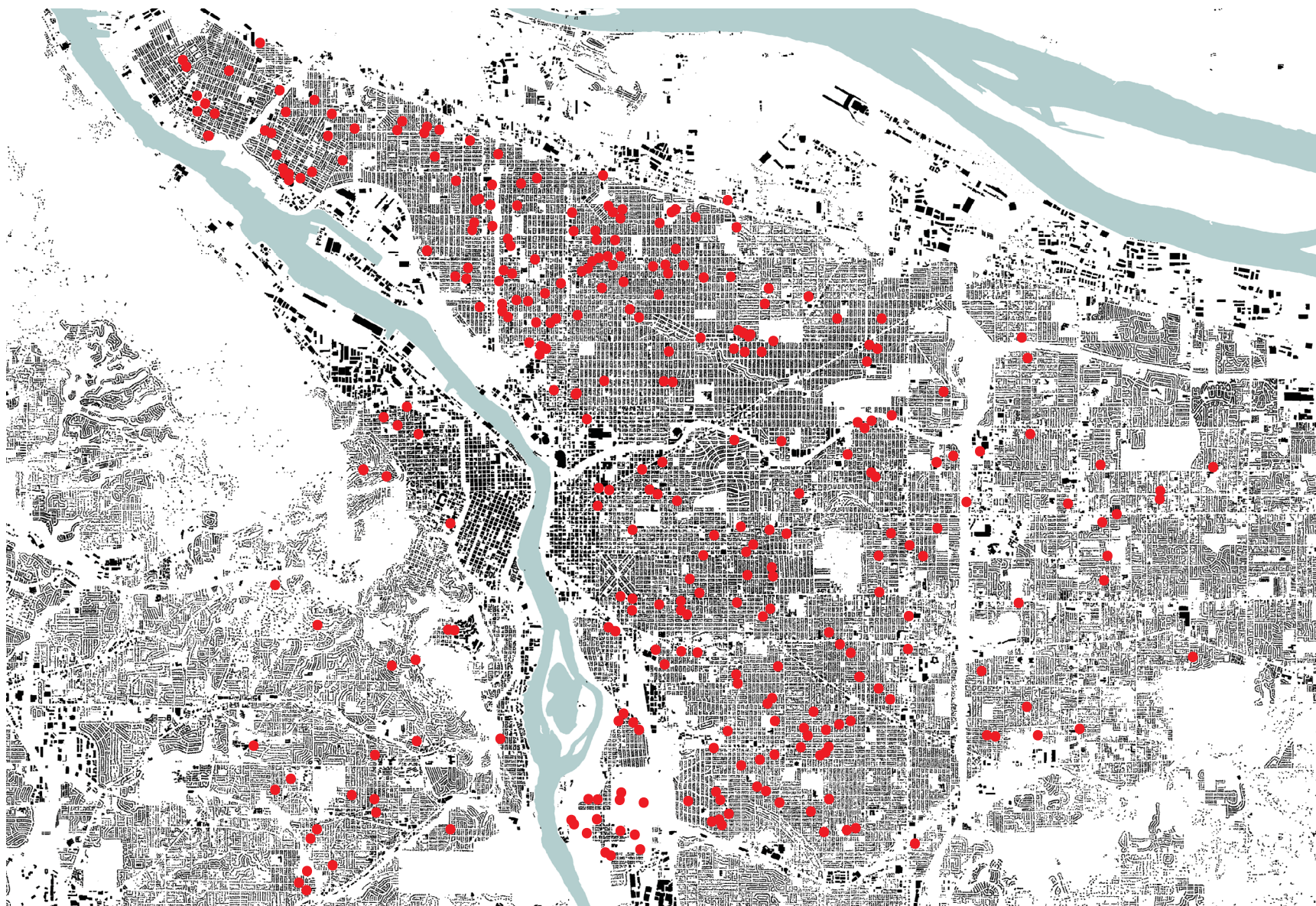

Data Source: *Portland Chronicle*

Figure 1.6 - Portland Residential Demolitions (2015) Chart

Development Models and Typologies

Strategies of Development

Post World War II, residential development strategies within the city of Portland, and indeed within the United States as a whole, have revolved primarily around the production of single family homes. Many typologies which were once built throughout city neighborhoods, such as courtyard apartments, bungalow courts, and duplexes fell out of favor due to the proliferation of the nuclear family, and perhaps more importantly, changing zoning rules which did not allow multi-family units previously available to most of the residential city properties. Unfortunately, recent shifts in demographics have shown that the typical single family dwelling typology may not be the most appropriate form of housing in order to sustain the changing and rising urban dweller population. While cities such as Portland are currently working toward more progressive residential infill development zoning, the current rules have not kept up with the demographic shift and demand for multi-family dwellings, middle housing models, and micro-housing communities. Furthermore, many of the fees associated with new residential construction – including such items as systems development fees (SDCs) – are geared toward a development which benefits from building the maximum amount of square footage on a lot in order to receive the highest profit. This broken fee and zoning system only further agitates the already volatile high price, low vacancy rate housing market seen currently in Portland. While the most typical residential developer follows a model which is primarily concerned with profit and is prone to find comfort staying well within the existing city rules and guidelines, there are some developers in Portland which have begun to form alternative models which present new possibilities in housing typologies and how they are constructed within current zoning regulations while still remaining profitable. These alternate models take advantage of housing choices such as accessory dwelling units (ADUs), tiny houses, pocket neighborhoods, and co-housing communities. However, while these alternative models are great examples to look at for forward thinking in housing choices and the method in which they can be implemented, they are still primarily concerned with being profitable, and rarely do they incorporate affordability into the development. A system which applies the notions of community and alternative dwellings used by the alternative for profit model toward a new type of development focusing heavily on affordability and neighborhood sustainability would present a new way of thinking about residential development to combat the current housing crisis in Portland.

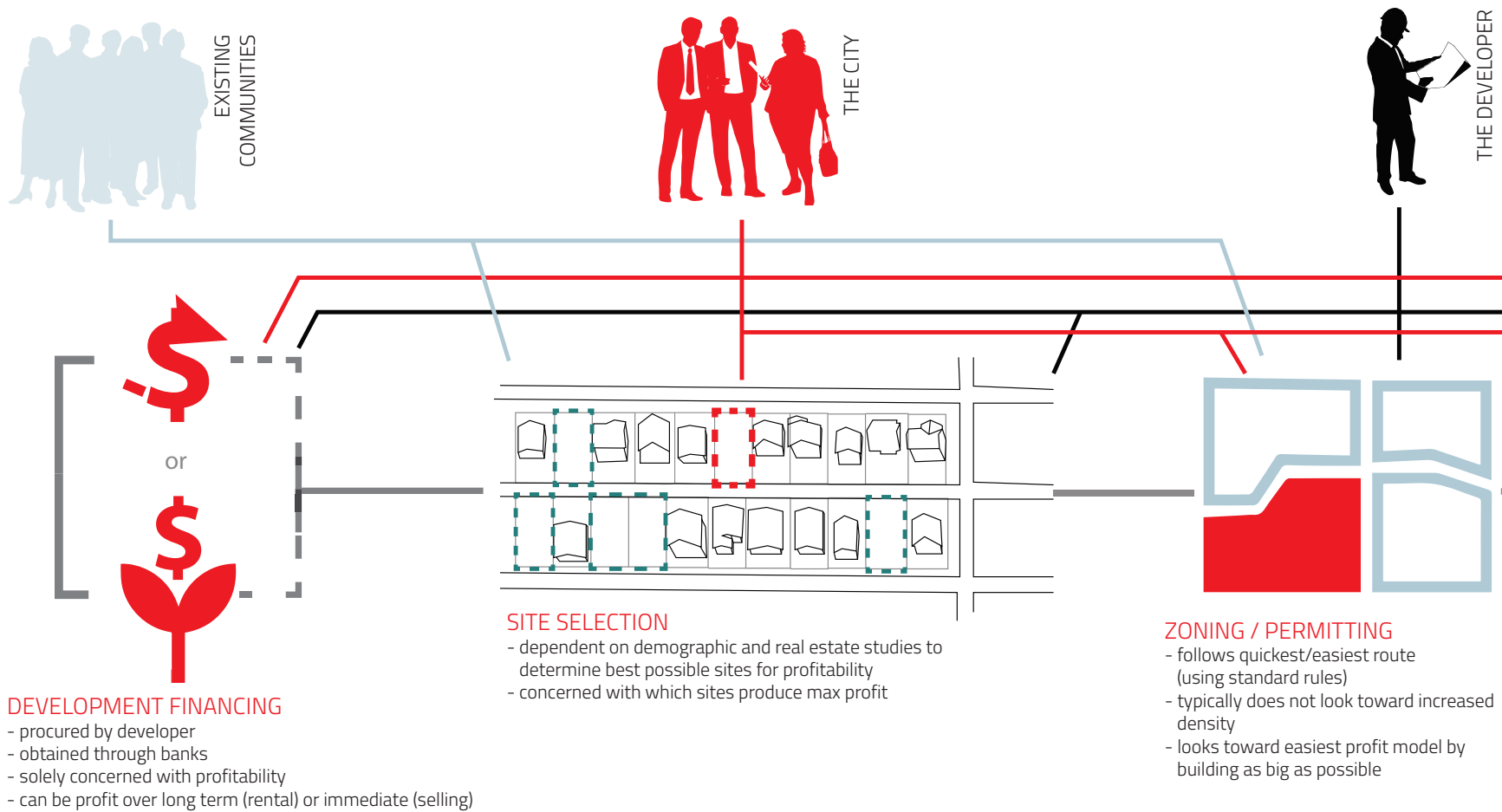

Typical *For Profit* Development

An overview of how a typical developer would go through the processes of developing a single family home and how the banks, residents, and community would all fit in within this system.

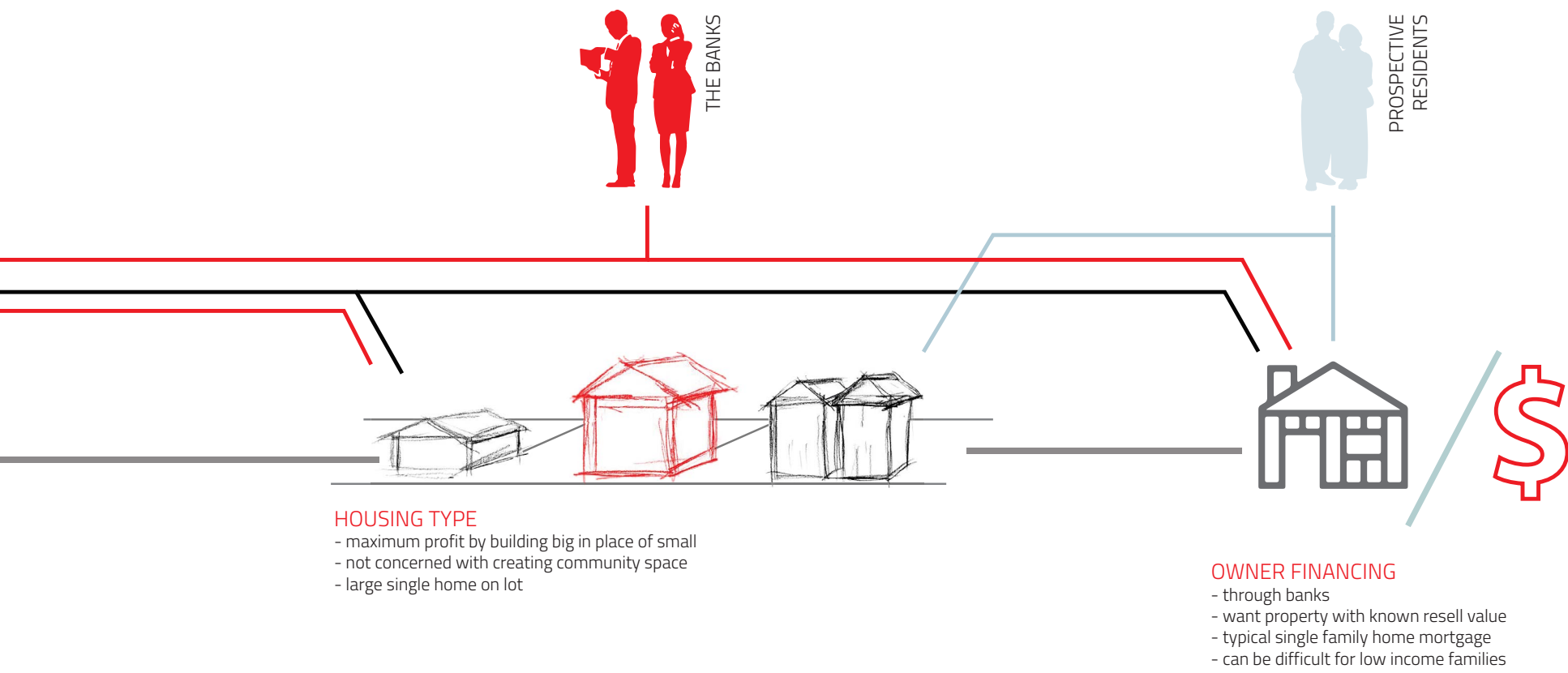
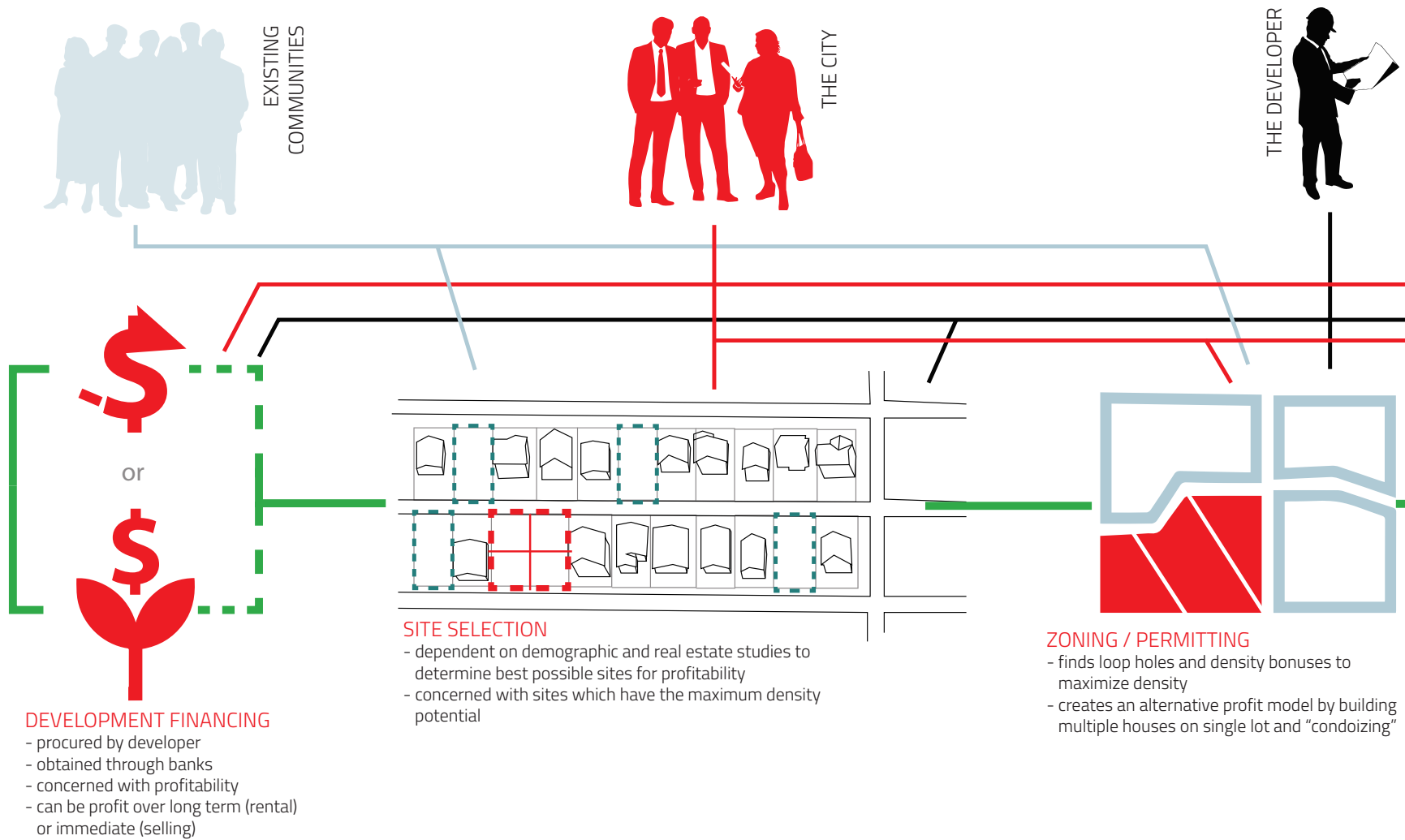
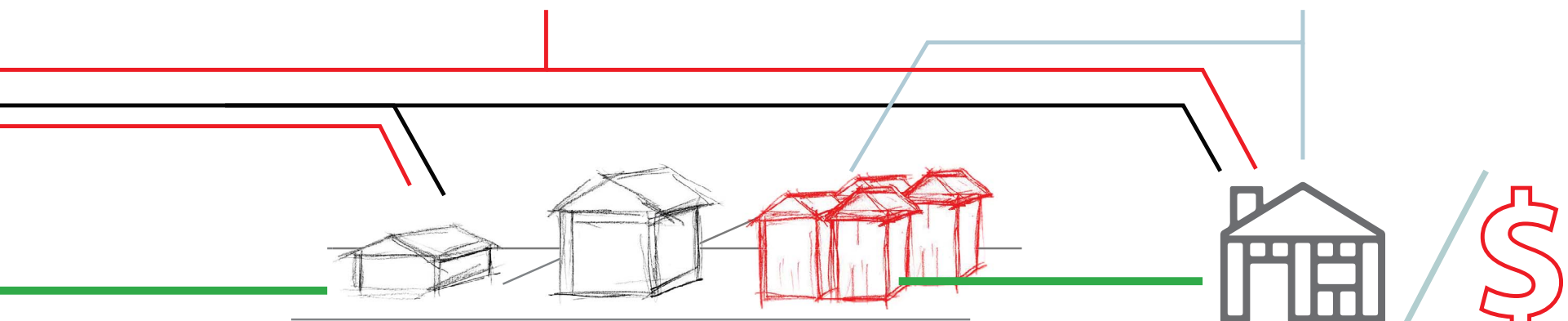

Figure 2.1 - For Profit Development Model



Alternative Micro-Housing Community For Profit Development

An general overview drawing from existing examples of micro-community housing developments in Portland neighborhoods and an alternative system of development geared toward creating a profit while integrating new typologies.



HOUSING TYPE

- typically smaller houses to increase density
- often concerned with creating community space
- usually preserves existing structures and adds auxiliary dwellings as allowed by zoning

OWNER FINANCING

- through banks
- may not be viable for low income families

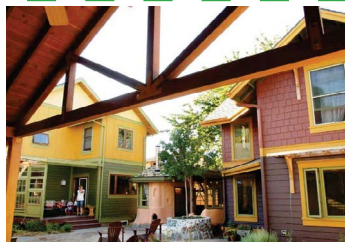

INSPIRATION - SABIN GREEN (PORTLAND, OR)

A pocket neighborhood in NE Portland developed by Orange Splot. A 75'x100' lot with an existing home was split to allow for a new home construction. ADUs were placed behind each home to end up with 4 total residences.

RESULTS

- provides multiple typologies for various/mixed demographics
- encourages community
- profitability through careful examination of zoning rules
- more energy efficient smaller homes
- may have little impact on housing costs and affordability

Figure 2.2 - Alternative For Profit Development Model

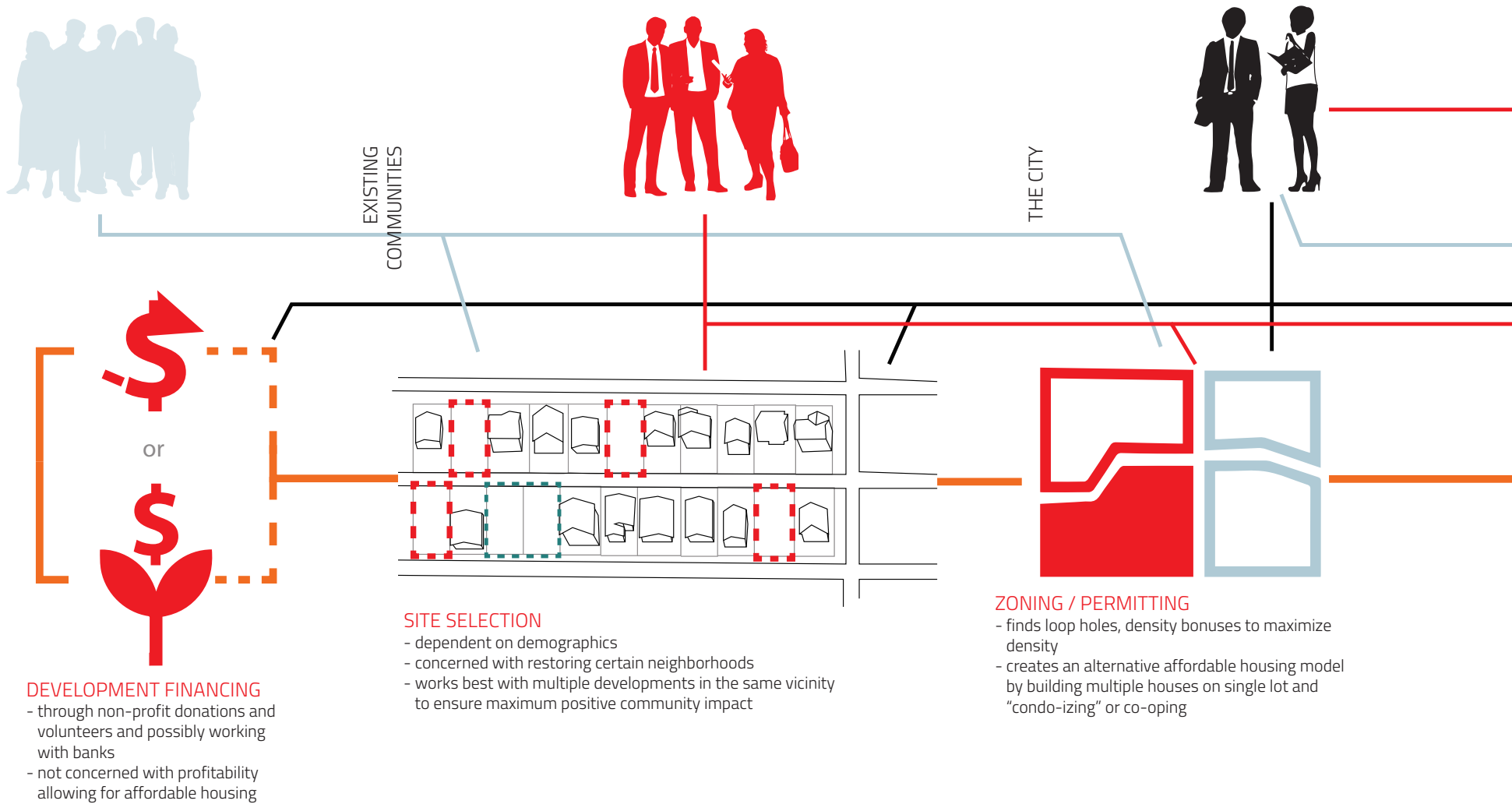

Alternative Micro-Housing Community *Non Profit* Development

A new notion of how a development plan can be created using most of the qualities of existing alternative development models while incorporating the idea of utilizing a non-profit organization to create permanent affordability within the units developed.

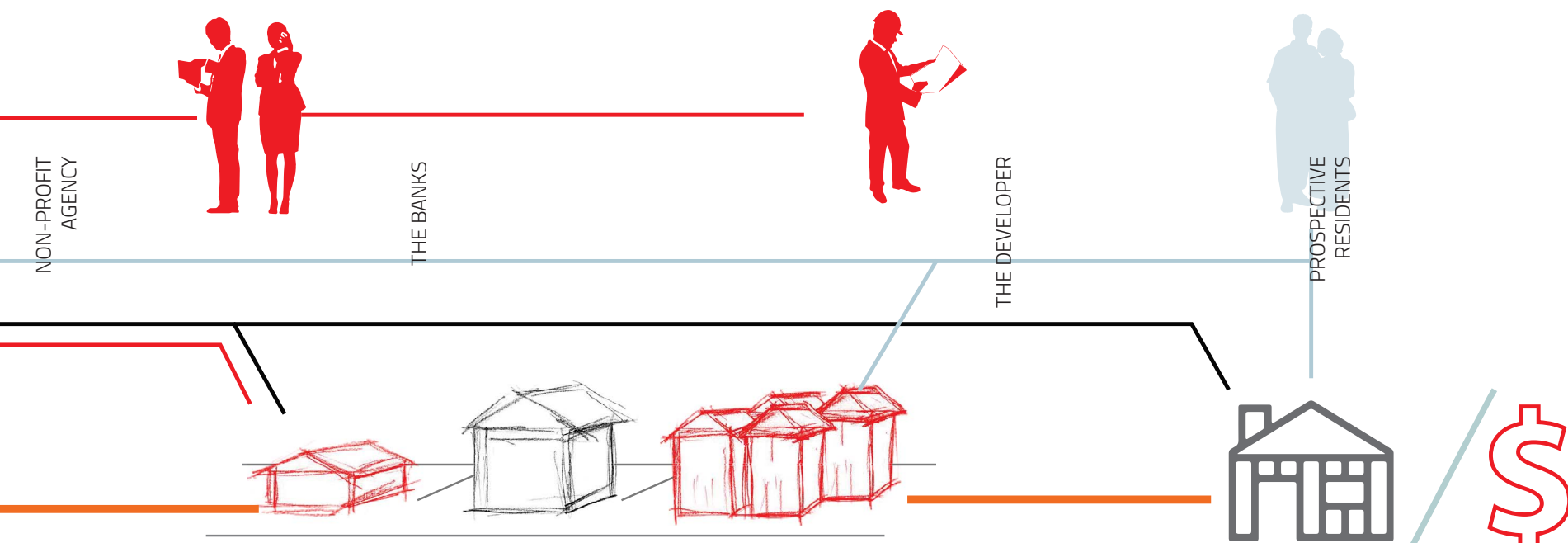

HOUSING TYPE

- typically smaller houses to increase density
- often concerned with creating community space
- could preserve existing structures and add auxiliary dwellings as allowed by zoning

OWNER FINANCING

- through non-profit
- does not require large down payment
- land remains owned by non-profit
- geared toward low income residents



PROUD GROUND
Dreams Start Here.

CLT's play an important role in community and neighborhood stability by creating multiple affordable developments within close proximity to each other.



INSPIRATION - PROUD GROUND COMMUNITY LAND TRUST
Proud Ground is a local Portland non-profit organization which works with community leaders, developers, and builders to provide affordable housing for families and individuals through the Community Land Trust model which supplies permanent affordability to the community.

RESULTS

- provides multiple typologies for various/mixed demographics
- encourages community
- retains affordability even after residents move
- more energy efficient smaller homes
- helps lower/maintain housing costs and affordability

Figure 2.3 - Alternative Non-Profit Development Model

Existing Alternative Models

There are many examples of housing developments that vary from the typical single family dwelling. While most of these fall within the zoning regulations of the city, they often utilize creative techniques for achieving the maximum density on a given lot. While the properties shown here are only a portion of these typologies located within the Portland area, it is a decent sampling of three different alternative models spread throughout the city boundary, showing the willingness of individuals and developers to utilize these types of residential developments. Furthermore, it is worth noting that there are many micro-housing communities throughout the city – typically tiny house villages – which skirt the zoning rules regarding maximum density regulations by simply placing multiple units in the backyard of existing single family homes. None of these types are listed here.

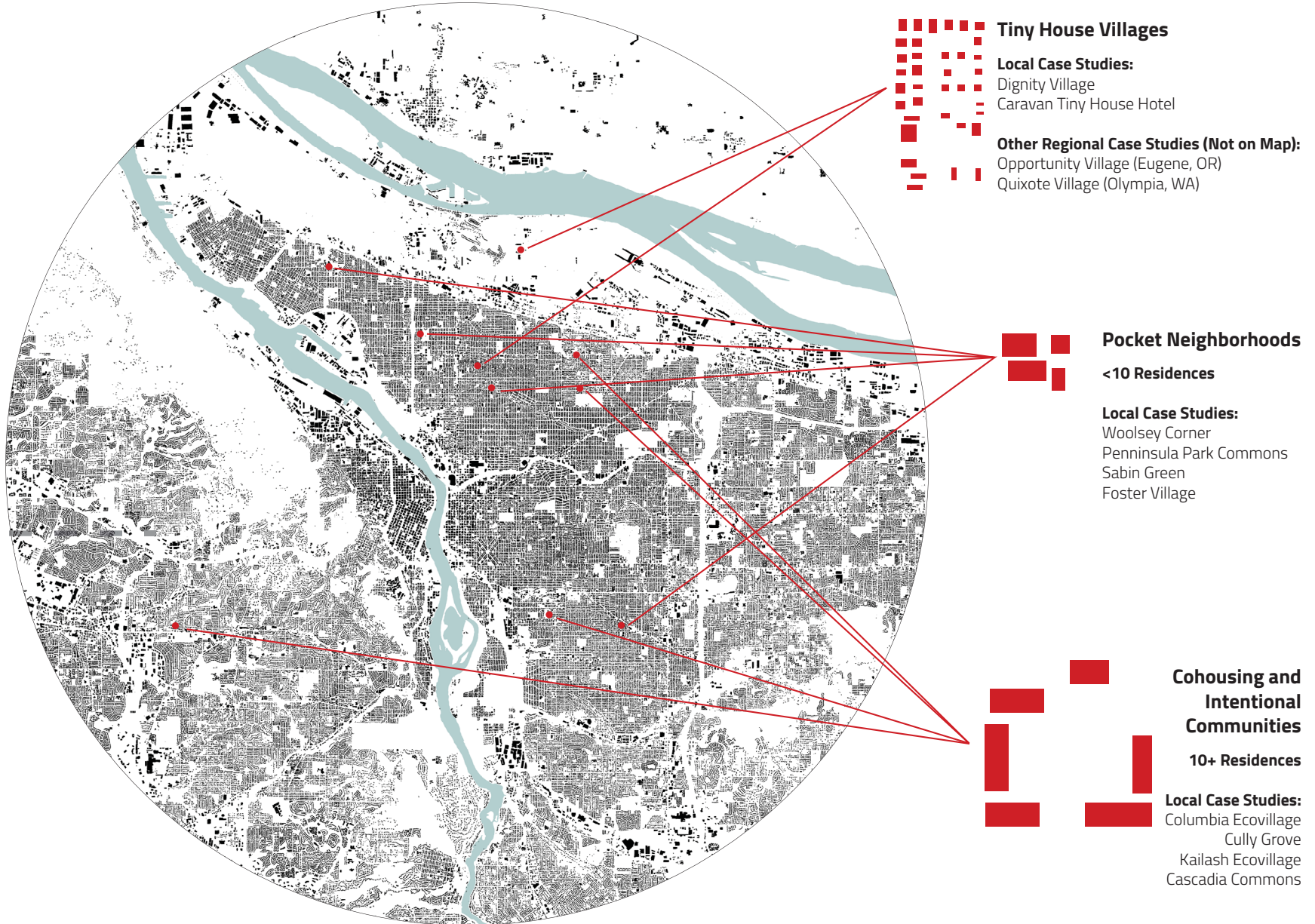

Figure 2.4 - Existing Local Micro-Communities

Micro-Community Typology Investigations

Pocket Neighborhoods

Pocket neighborhoods are micro-communities often made up of around 4 or more residential units utilizing shared spaces and resources. These can range from planned cottage developments on large lots zoned for multi-family residential to simply a set of houses located next to and behind one another which have taken out any fencing and have created shared spaces in-between the units. The main inspiration for the concepts presented here is drawn from pocket neighborhoods which creatively incorporate accessory dwelling units (ADUs) with existing residences either through the use of rehabbing an existing structure – such as a garage – or building a completely new unit.

POCKET NEIGHBORHOOD TYPOLOGY

CONCEPT A

Description

Using the available space within the lot of an existing home, two separate accessory dwelling units (ADUs) add a higher level of density without requiring the need to demolish existing infrastructure or take away from the current neighborhood aesthetic. Placing the ADUs toward the rear of the lot creates an opportunity for a shared space between all three units.

Expected Average Capacity:

8-10

Anticipated Residents:

Main House: Small Family

ADUs: Singles and/or Couples

Program:

1 Main House

2 Accessory Dwelling Units

Private Outdoor Space for Residents

Shared Front Outdoor Space

Level of Community and Privacy

This layout allows for a front yard/garden space which can be designated to be either open to the surrounding community or as a private space for the main house. This would allow for the backyard/garden space to be either shared between all units or just the ADUs.

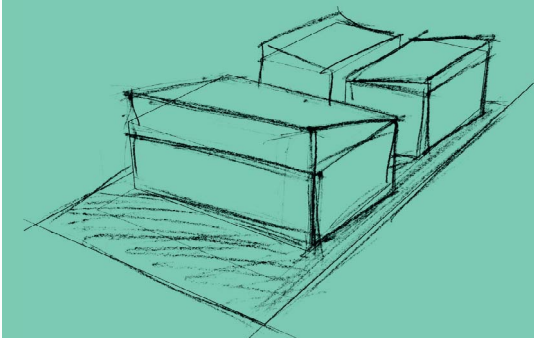
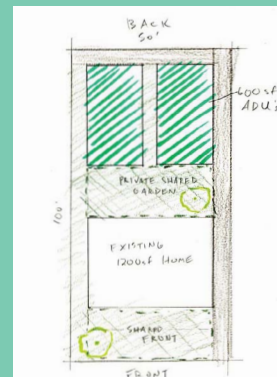

POCKET NEIGHBORHOOD TYPOLOGY

CONCEPT B

Description

Going away from the notion of any type of larger home this plan simply attempts to place four separate small homes into a layout which is conducive to increasing density, provides an alternative housing style, and builds community among the residents.

Expected Average Capacity:

6-8

Anticipated Residents:

Singles and/or Couples

Program:

4 Small Individual Homes
Private Outdoor Space for Residents

Level of Community and Privacy

This layout does not include a community space that is open to the general public. Instead it focuses on providing places for the residents to gather and have community within their own small spaces while at the same time retaining individuality through free standing structures.

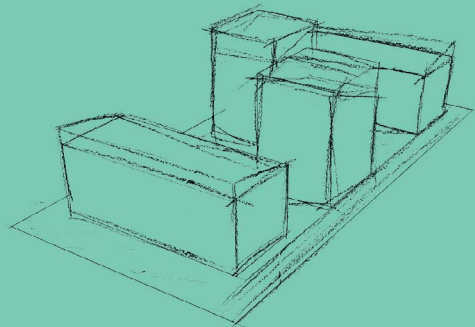
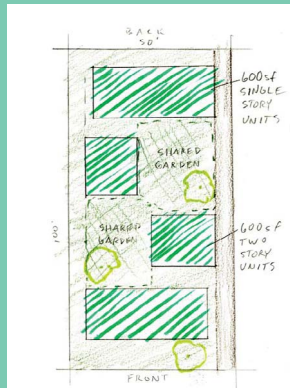

POCKET NEIGHBORHOOD TYPOLOGY

CONCEPT C

Description

Two small homes and two detached bedrooms provide an opportunity to create a mixed micro-community of families and single people. One opportunity within this situation would be for one or both of the houses to contain communal spaces (kitchen, bathroom, etc.) open to the residents of the detached bedrooms.

Expected Average Capacity:

8-10

Anticipated Residents:

Main Houses: Small Family
Detached Bedrooms: Singles and/or Couples

Program:

2 Small Houses
2 Detached Bedrooms
Private Outdoor Space for Residents

Level of Community and Privacy

This layout does not include a community space that is open to the general public. Instead it focuses on providing places for the residents to gather and have community within their own small spaces while at the same time retaining individuality through free standing structures.

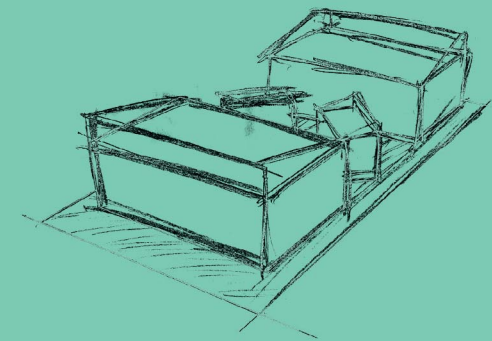
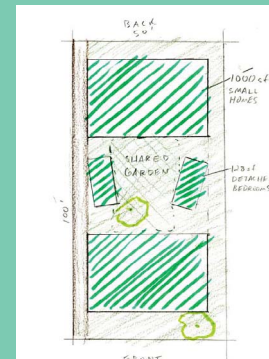

Figure 2.5 - Pocket Neighborhood Typologies

Micro-Community Typology Investigations

Tiny House Villages

Tiny house villages are communities made up of a number of tiny (300sf or less) homes. Typically, these are developed as alternative dwellings behind an existing single family residence with a large lot in which the tiny home users can share common spaces both within the backyard area and portions of the existing home such as a common kitchen and/or dining area. Most instances of this type of development within Portland consists of tiny homes which are always on wheels in one way or another to avoid zoning regulations which would otherwise not allow permanent structures such as these.

TINY HOUSE VILLAGE TYPOLOGY

CONCEPT A

Description

Six tiny home units share both a garden space and a common house space which may or may not be occupied, but will certainly include communal kitchen and bathroom spaces.

Expected Average Capacity:

7-9

Anticipated Residents:

Common House: Singles and/or Couples

Tiny Homes: Singles and/or Couples

Program:

6 Tiny Homes

1 Common House

Private Outdoor Space

Community Outdoor Space

Level of Community and Privacy

This layout accommodates both a community garden space to be used by others within the neighborhood as well as a private space for the residents to use and build their own micro-community. The community garden space does not need to be limited to gardening, but can be changed to a small neighborhood park and/or gathering space.

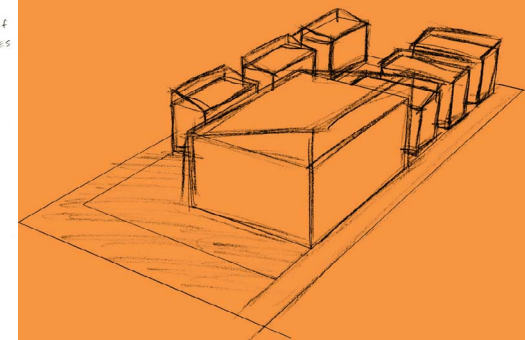
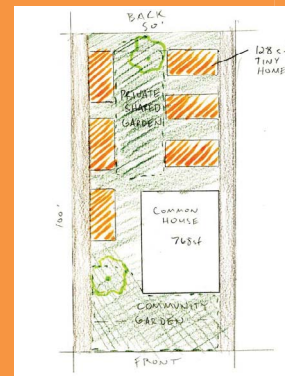

TINY HOUSE VILLAGE TYPOLOGY

CONCEPT B

Description

This layout maximizes the number of tiny houses available by not including a larger communal home. Due to the lack of this space, this concept would be most viably suited for those who are able to live by the simplest means (i.e. hotplate kitchens, and limited bathroom options) or have the option of using other off site facilities.

Expected Average Capacity:

9-12

Anticipated Residents:

Singles and/or Couples

Program:

9 Tiny Homes
Community Outdoor Space

Level of Community and Privacy

A large front and side yard space provide an open community garden space to the neighborhood and helps to increase the level of micro-community within the village itself.

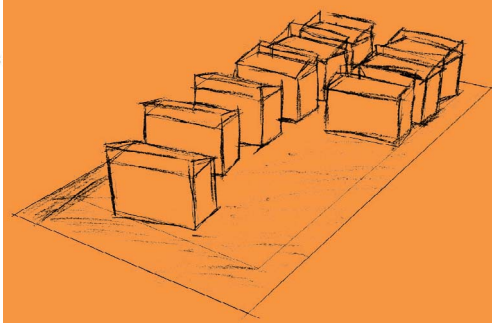
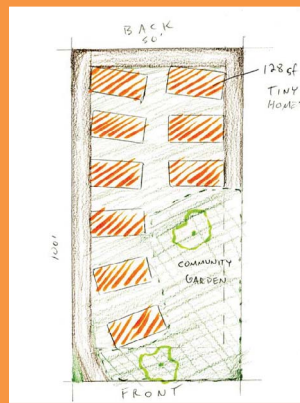

TINY HOUSE VILLAGE TYPOLOGY

CONCEPT C

Description

A small home at the front of the lot provides privacy to a micro-community of six tiny homes toward the back. This provides the opportunity for residents within the larger home and at the same time communal spaces needed by the tiny home dwellers.

Expected Average Capacity:

7-9

Anticipated Residents:

Main House: Small Family or Couples
Tiny Homes: Singles and/or Couples

Program:

1 Small Communal Home
6 Tiny Homes
Private Outdoor Space
Shared Front Outdoor Space

Level of Community and Privacy

This layout allows for a front yard/garden space which can be designated to be either open to the surrounding community or as a private space for the main house. This would allow for the backyard/garden space to be either shared between all units or just the tiny home cluster.

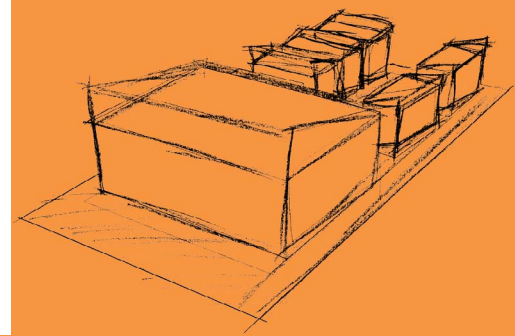
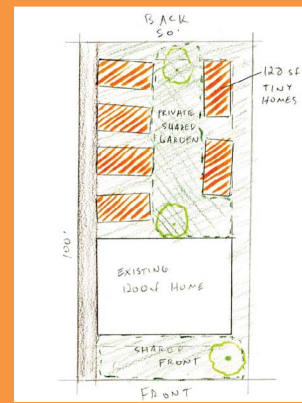

Figure 2.6 - Tiny House Village Typologies

Micro-Community Typology Investigations

Middle Housing

Middle housing, often referred to as The Missing Middle, is a type of housing that was regularly developed within city neighborhoods prior to World War II and consisted of a variety of typologies including courtyard apartments, bungalow courts, duplexes, triplexes, and fourplexes. After the war, these types faded from neighborhoods because of changing zoning rules and family ideologies; however, with the current shifting demographics and residential landscape of cities such as Portland, many forward thinking developers are seeking ways to try and reincorporate these housing options back into city neighborhoods as a way to deal with increasing populations and rising costs.

MIDDLE HOUSING TYPOLOGY

CONCEPT A

Description

This is just a typical missing middle housing example of what might be considered a bungalow court which in this case combines a mixture of connected and individual units centered around a shared courtyard.

Expected Average Capacity:

10-12

Anticipated Residents:

Singles and/or Couples

Program:

3 - 704sf Units

3 - 544sf Units

Private Outdoor Space for Residents

Level of Community and Privacy

This layout focuses on an inward community space with the shared courtyard to be used by the surrounding residents.

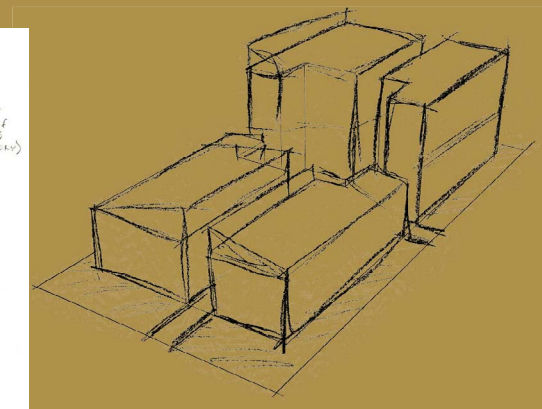
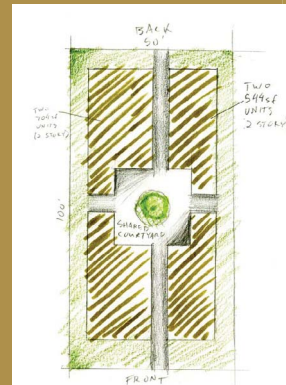

MIDDLE HOUSING TYPOLOGY

CONCEPT B

Description

This is another typical missing middle housing model exploring the notion of bringing back the triplex housing model into the urban fabric of Portland neighborhoods.

Expected Average Capacity:

6-8

Anticipated Residents:

Small Families, Singles, and Couples

Program:

3 Connected Units

Private Outdoor Space for Residents

Level of Community and Privacy

In the current scheme the shared outdoor space is at the back of the property allowing for an inward community developing space to be utilized by the residents of the three units. However, the layout could easily be flipped to allow the outdoor space to become a neighborhood community space toward the front of the property if a viable option for the location.

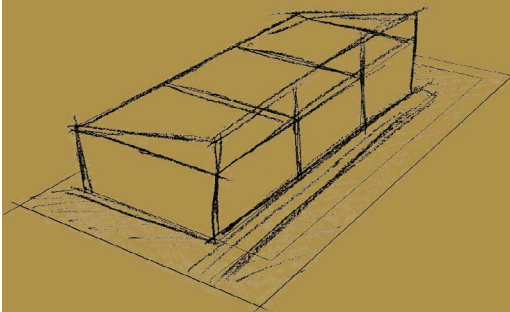
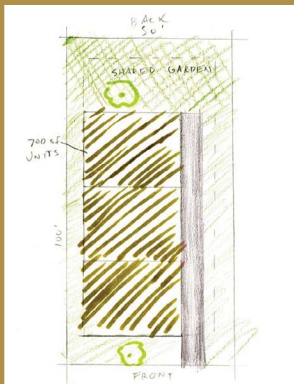

MIDDLE HOUSING TYPOLOGY

CONCEPT C

Description

Utilizing the concept of either the fourplex or the courtyard apartment, this layout attempts to truly maximize the density of the space and allow for micro-community development.

Expected Average Capacity:

8-10

Anticipated Residents:

800sf Units: Small Family

600sf Units: Singles and/or Couples

Program:

2 - 800sf Units

2 - 600sf Units

Private Outdoor Space for Residents

Level of Community and Privacy

In the current scheme the shared outdoor space is hidden behind a larger unit allowing for an inward community developing space to be utilized by the residents of the three units. However, the layout could be changed to where that unit sits at the back to allow the outdoor space to become a neighborhood community space toward the front of the property if a viable option for the location.

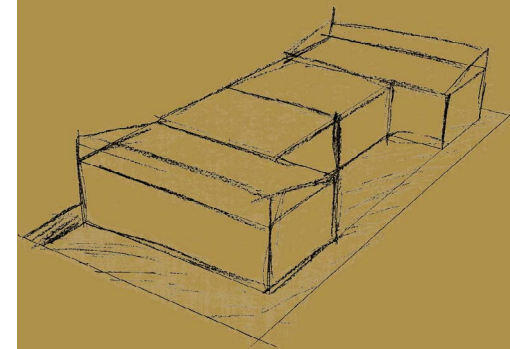
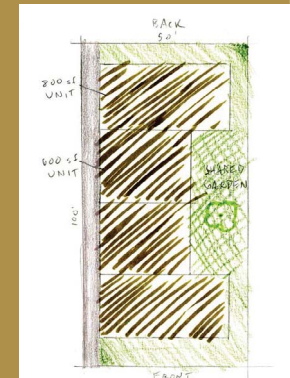
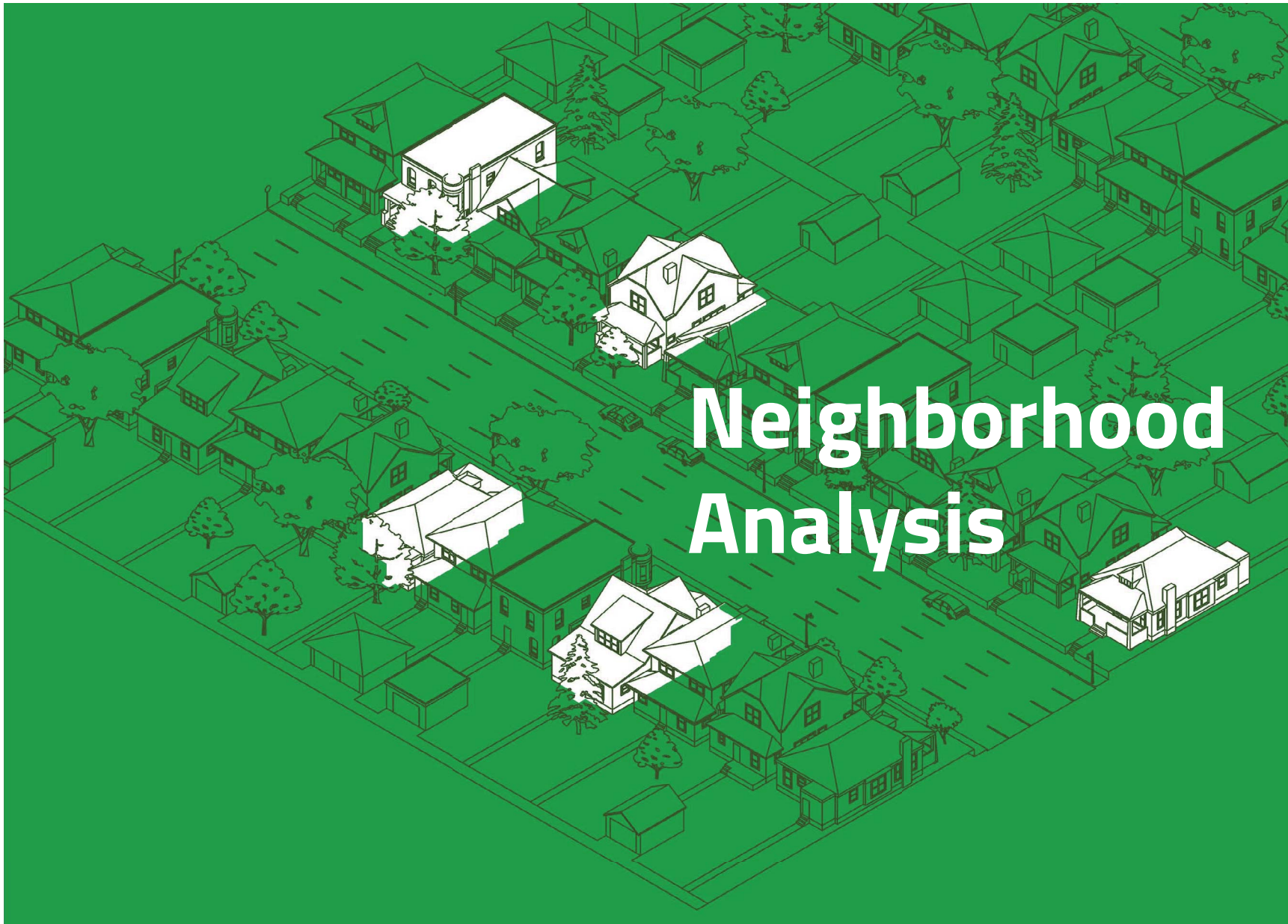

Figure 2.7 - Middle Housing Typologies



Finding the Ideal Site

When selecting a neighborhood for this project proposal it was important to factor in sites which were currently being developed to provide a realistic alternative example to the current development plans. By starting with the demolition permits on file at the beginning of 2016, neighborhoods were narrowed down to those containing multiple sites slated for demolition, and from there the individual sites were studied to find those with the most potential for micro-housing communities to be developed. The Foster-Powell neighborhood in Southeast Portland showed the most potential with three separate sites containing older homes which were to be torn down. Furthermore, each of these sites presented unique potentials in order to work around typical zoning regulations which promote single family homes to be built on the majority of sites within this neighborhood. The first site, at 3815 SE 70th Ave, while designated R5 showed potential toward micro-community development because it is situated next to an additional empty R5 lot. With this scenario, a developer could easily rehab the existing home, turn the existing garage into an ADU, and build a new small home on the empty lot with an additional ADU behind it. The second site, at 8035 SE Center St, designated as Commercial General (CG) zoning afforded more units to be built within this single site, along with the possibility of integrating some form of small community commercial building to benefit the micro-community. The third site, at 7932 SE Raymond St, situated on a large 6000 square foot lot and zoned R1 could be developed with six separate living units while staying within the current zoning regulations. Additionally, the demographics for this neighborhood proved to be typical for what is being seen throughout the city of Portland as a whole – most importantly, home prices and rental rates are rising at an extreme rate, and the overall population has less low income residents than it did 5 years ago. The neighborhood as a whole as well as the individual available sites provide an ideal scenario for the proposal of a new system of residential development.

Neighborhood/Site Investigation

Foster Powell (SE Portland)

This southeast Portland neighborhood has three unique properties slated for a 2016 demolition which will more than likely be replaced by one or two large single family dwellings per lot. These provide an interesting opportunity of developing various micro-housing communities all within a single community.

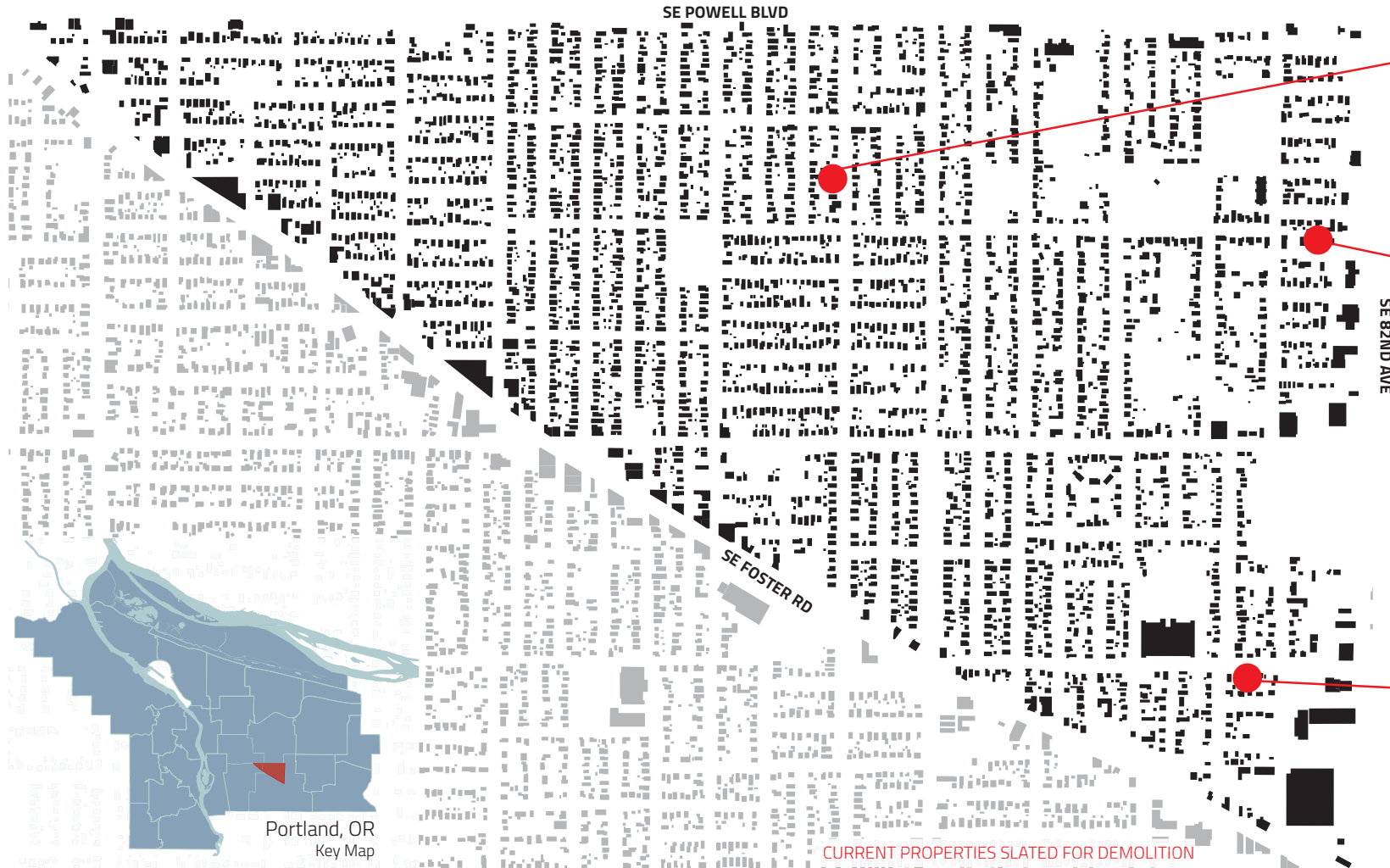
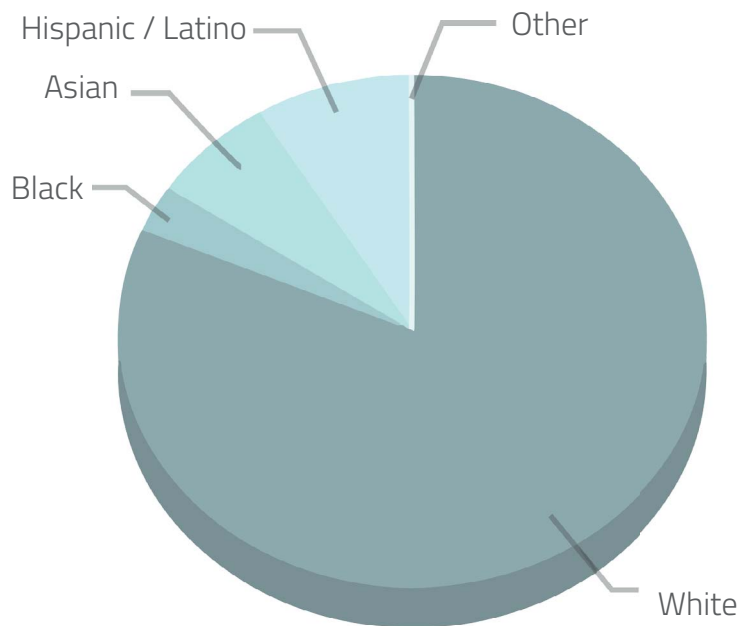



Figure 3.1 - Site Investigations

Foster Powell Neighborhood Demographics

A demographic study of the neighborhood is a good example of what is currently happening throughout many neighborhoods throughout the city including rising home and rental prices, less affordability than ever before, and plummeting vacancy rates.



Race Distribution 2014

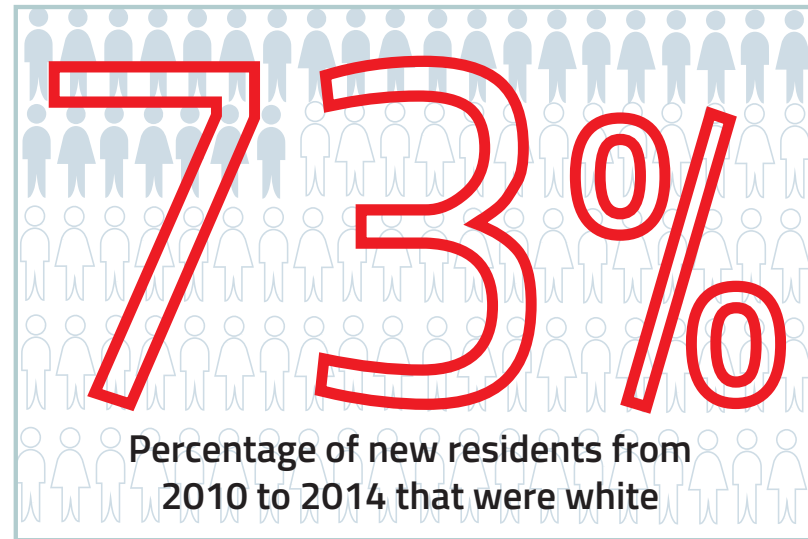

Median Household Annual Income

2010 **\$45,238**

2014 **\$53,181**

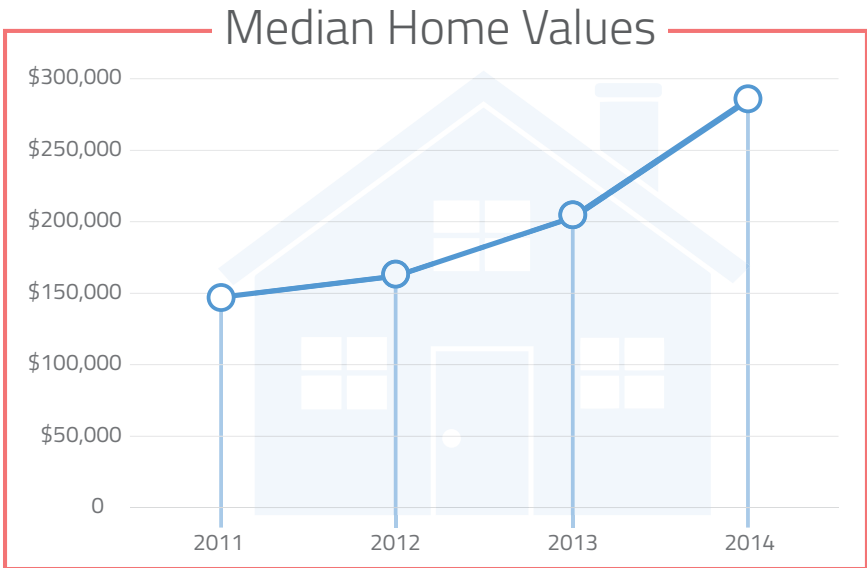

Housing Affordability

	Studio	1-BR	2-BR	3-BR	Homeownership
Avg. Portland Household	YES	YES	YES	YES	YES
3-Person Extremely Low-Income	NO	NO	NO	NO	NO
3-Person Low-Income	YES	YES	NO	NO	NO
3-Person Moderate-Income	YES	YES	YES	NO	YES
Couple with Family	YES	YES	YES	YES	YES
White	YES	YES	YES	YES	YES
Black	NO	NO	NO	NO	NO
Latino	YES	NO	NO	NO	NO
Native American	NO	NO	NO	NO	NO
Asian	YES	YES	YES	NO	YES
Senior	YES	YES	NO	NO	NO
Single Mother	YES	NO	NO	NO	NO
Foreign-Born	YES	YES	NO	NO	YES

Rental Vacancy Rates

1 BEDROOM 1.7%

2 BEDROOM 2.3%

3 BEDROOM 0.0%

Figure 3.2 - Foster Powell Neighborhood Demographics

Initial Design Possibilities

Simple massing models and generic floor plans provided initial thoughts toward design possibilities and layouts of the three sites selected. At this point, with the options offered by the three sites, the most logical exploration to move forward with was the Pocket Neighborhood typology. Keeping the overall scheme simplified would allow for a system to develop which could be broadly applied throughout not only the sites of this study, but to any sites within Portland which have micro-community development potential.

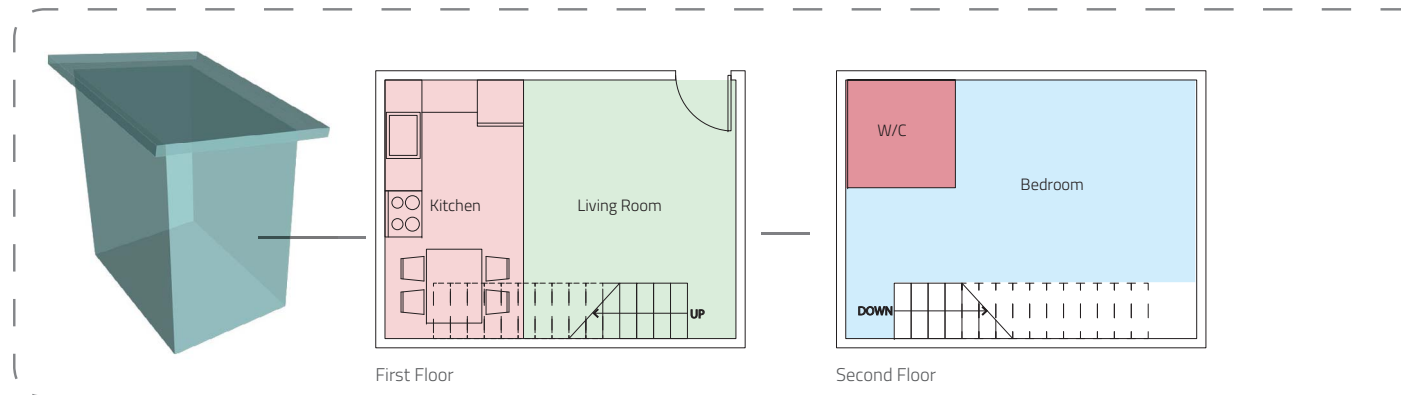
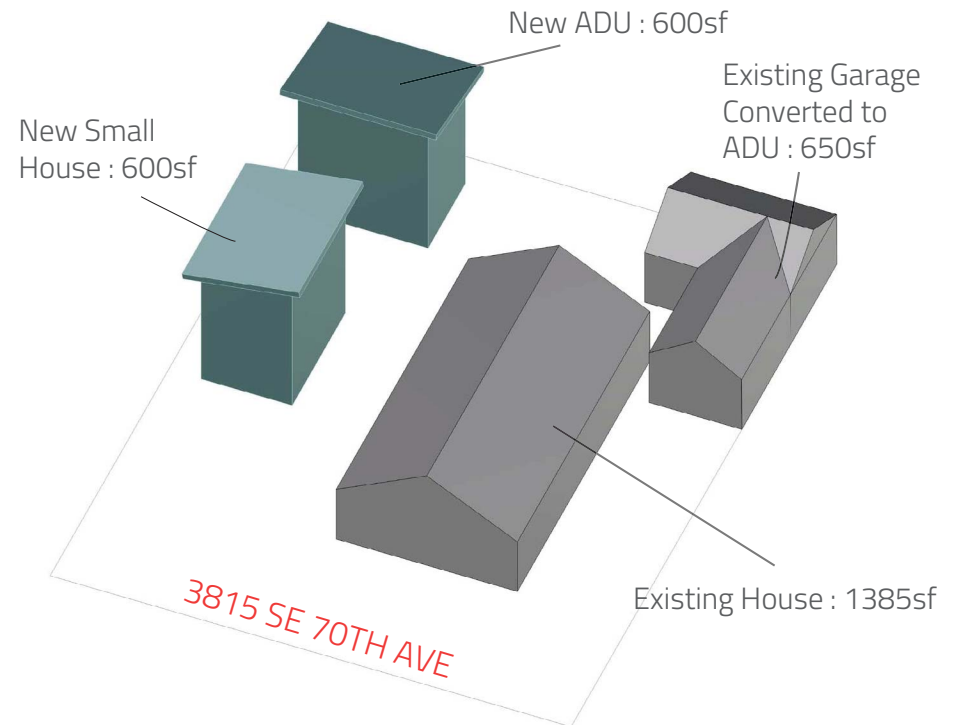

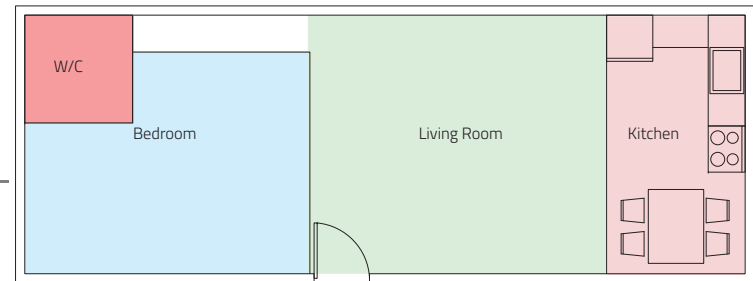
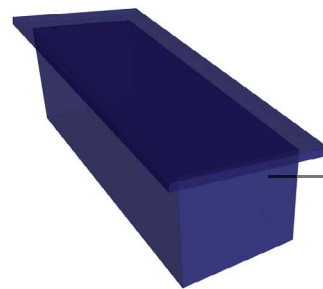
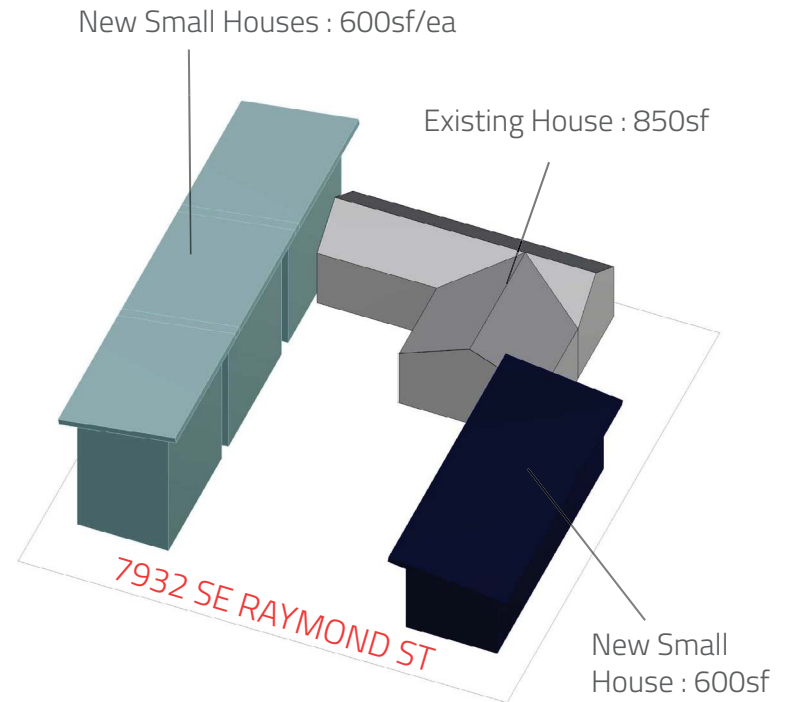
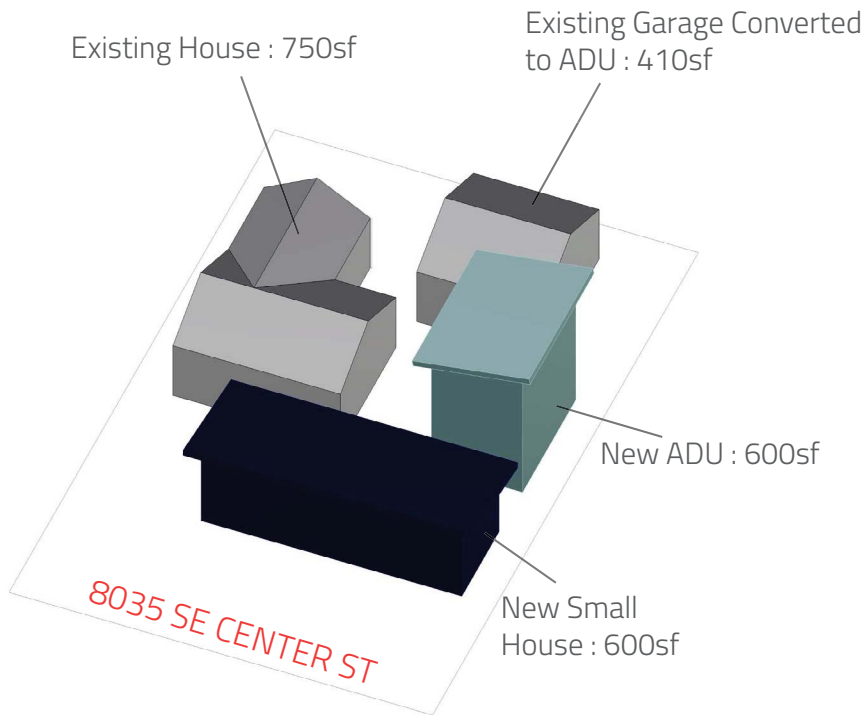

Figure 3.3 - Initial Design Investigations



Integrating Affordability and Community

Through the use of an alternative model run by a non-profit organization the proposed design seeks to incorporate permanent affordability and a variety of community features within each site. Similar to a community land trust (CLT) model, the non-profit would retain ownership of the land on which small residences are built, and will work with low income families and individuals in order to acquire home loans to purchase the residences. At any time, the home owners may re-sell their home with any appreciation, but the land will still remain under the ownership of the non-profit which helps pave a way toward homes which are always affordable for low income families. The community centers located within each site will primarily be built using federal and local grants to help lower the construction cost and will provide some form of benefit to the community including any number of amenities depending on the need of the neighborhood, including examples such as community outreach, education, workshops, or entertainment. These centers would not only be a benefit to the micro-housing community in which they reside, but would purposefully serve the neighborhood the community is situated. Providing beneficial community assets such as these to the neighborhood would be a key component to garnishing support from fellow neighbors who may otherwise be adverse to this type of development next to their homes.

Designing a New System

The proposed construction methodology of this design would be to progressively integrate the various components and build upon the existing infrastructure. Instead of razing the current home, the non-profit would seek to gain a steady flow of rental income to cover costs of construction of the newer tiny houses, small homes, and community centers. Once the micro-community has been built up, this home could either remain a rental, be sold using the CLT method, or converted into a shared indoor community space for the residents, such as a communal kitchen or dining hall. This conversion of the existing property would be determined by the needs of a particular micro-housing community which would most certainly vary depending on the size and type of lot and the amount of tiny (about 300 square feet or smaller) homes being implemented versus small homes (from around 300 to 1000 square feet). Additionally, the planned use of the community center would be determined by a variety of variables including the expected resident types, zoning rules, and site location. Regardless of how these design specifics would play out from site to site, the general development system principles would remain – non-profits would utilize a community land trust model to build up micro-housing and community buildings toward becoming an integral part of uplifting neighborhoods and promoting permanent affordability.

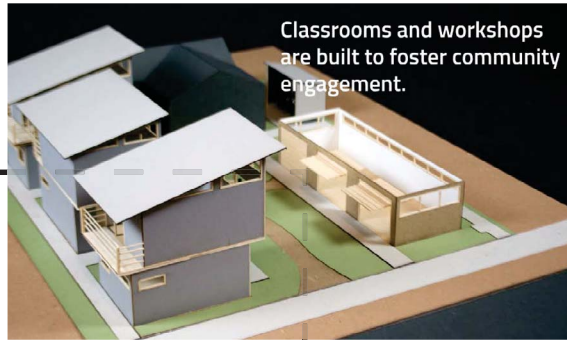
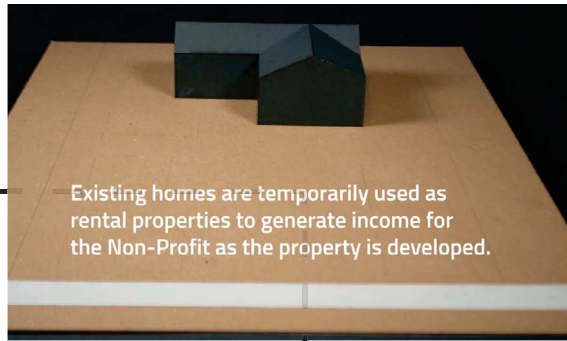
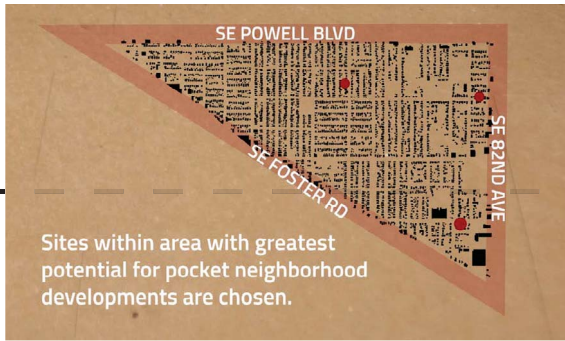
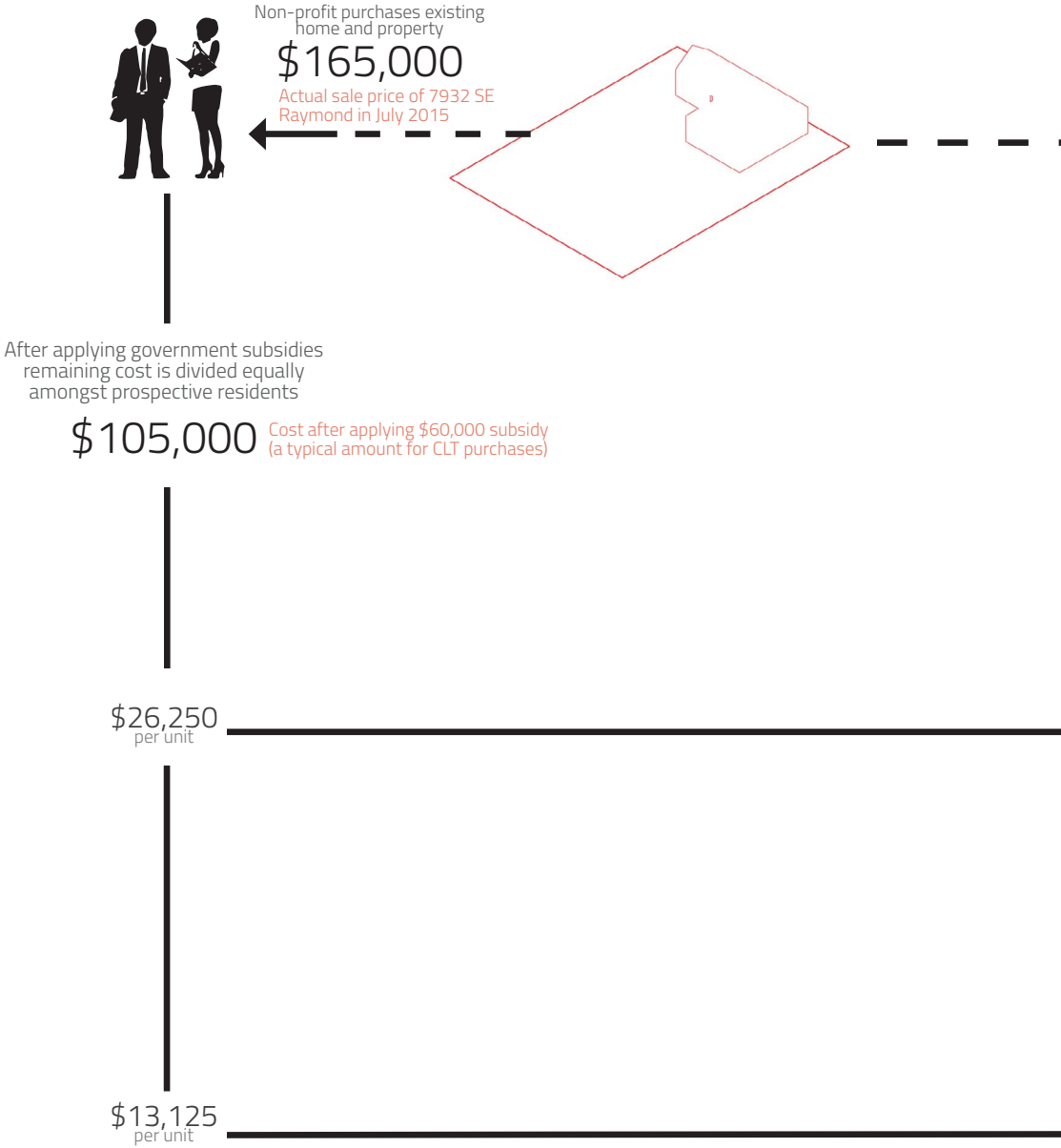

Figure 4.1 - Micro-Housing Community Development Proposal

Development Cost Analysis

A crucial step in developing an alternative development system is to provide a financial scenario in which the costs for units remain affordable while successfully integrating the costs of community buildings and other resources to be used by the micro-community. The scenario outlined here utilizes real world numbers for the Raymond Street property including the actual most recent sale price of the property, incorporating typical grant values for the area, and proposing the most common form of mortgage rates and associated fees used by Proud Ground – a local Portland community land trust organization. Just as the non-profit oversees the construction of the property, they will remain financial managers of the site in order to take advantage of existing connections with local lenders and help find the perfect candidates for residencies and community involvement.



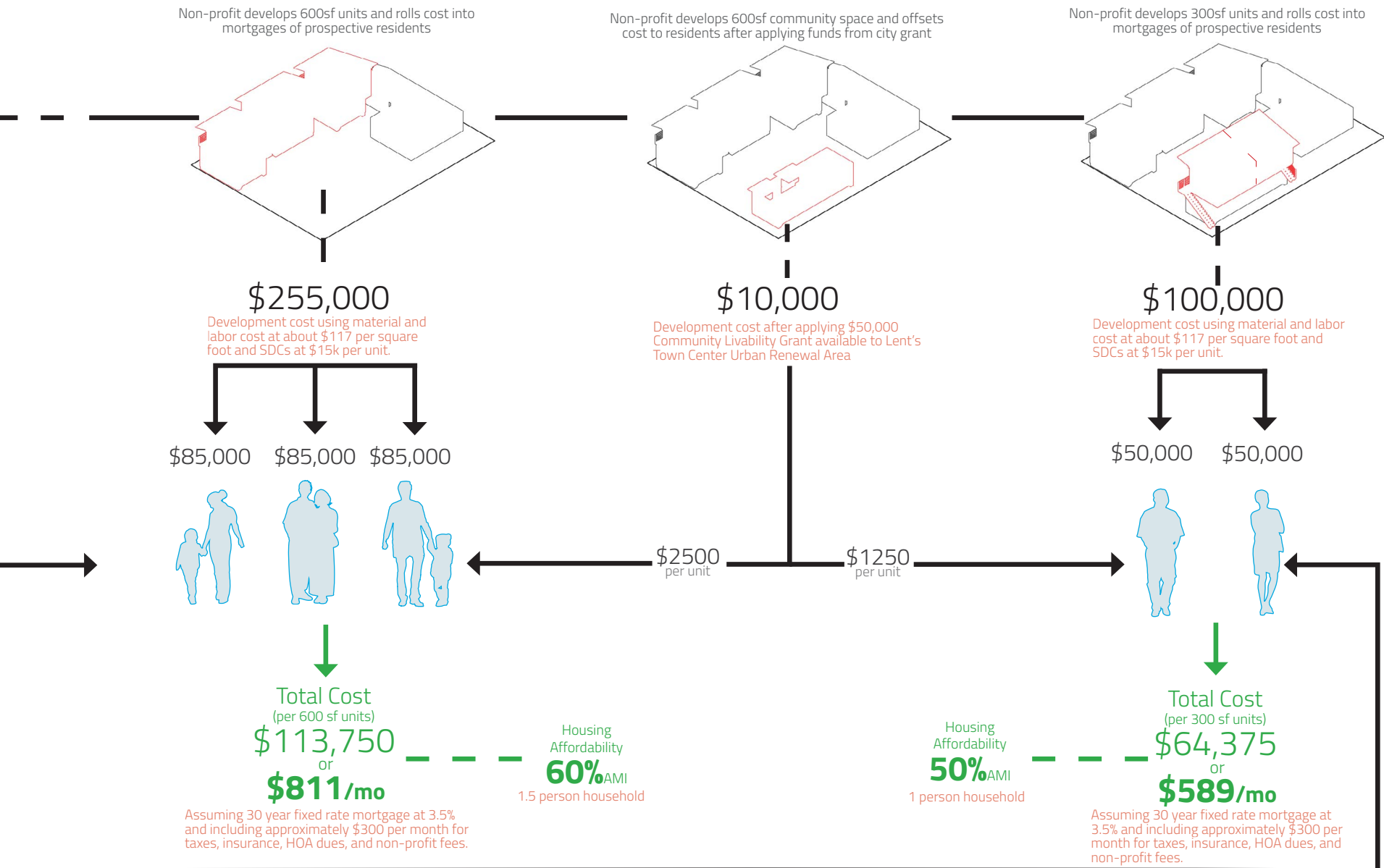
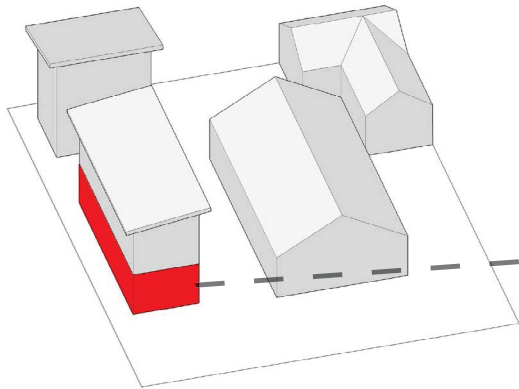

Figure 4.2 - Cost Analysis Diagram



SOCIAL SERVICES CENTER

Residents of community can volunteer to be a part of programs geared toward providing direct social services to residents in need.

Possible services provided:

- Providing meals to age in place elderly within neighborhood
- Neighborhood outreach to show benefits of CLT program and how to get involved
- Organizing and cross-promoting events at other community spaces



SE FOSTER RD

ARTIST WORKSPACE / GALLERY

Residents use community space to create and present artwork



Possible uses include:

- Working space for artist residents of micro-community
- Outreach and education of local neighborhood residents through various programs
- Display space for events organized by non-profit to showcase the benefits of the community space

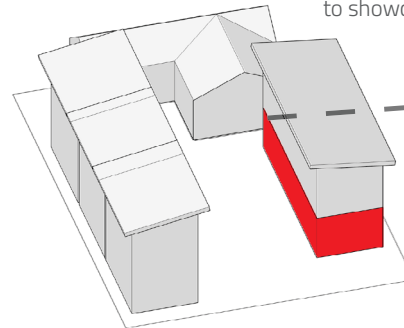

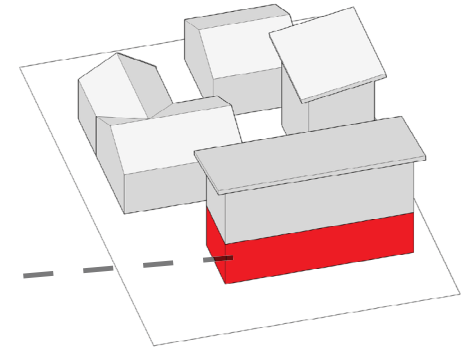
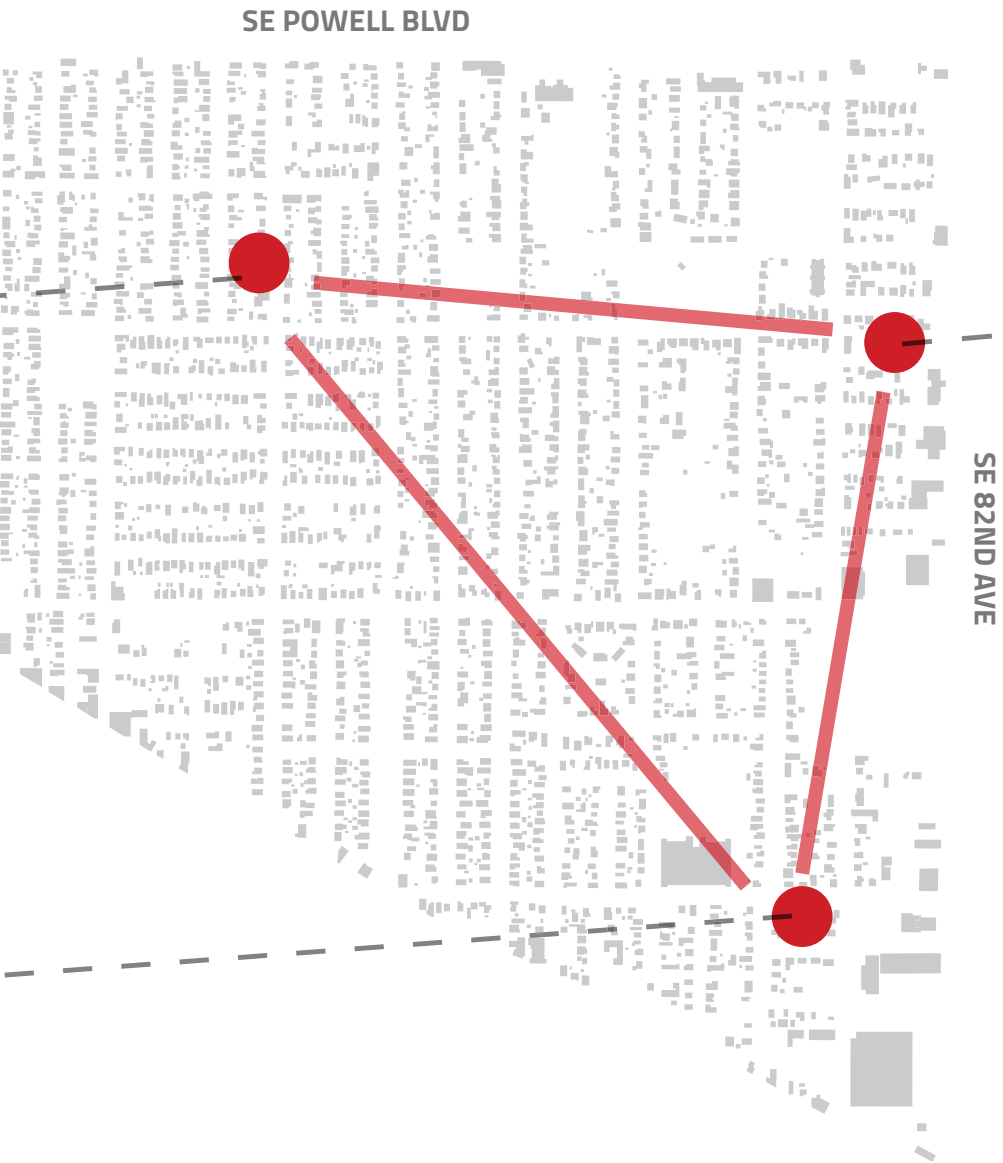

MICRO-BUSINESS MARKET

Storefront space for artisans, craftsman, and local neighborhood vendors

Possible uses include:

- Weekly events showcasing goods produced by rotating community artisans
- Classes during non-market days to help prospective local micro-business vendors
- Space to promote and sell goods made at artist workspace

Making Community Connections

Separate micro-housing communities begin to provide positive impacts and stabilization to neighborhoods by offering spaces beneficial to entire community through outreach, education, entertainment, and social services.

Figure 4.3 - Community Connection Diagram

Breaking the Typical Form

While typical recent residential developments demolish existing homes and replace them with much larger – often around 3000 square foot – homes, this proposed design takes that design notion and breaks that physical form into many pieces while keeping the existing building. This process proposes that if neighborhoods are accepting of the general large form already being implemented, then designing and constructing smaller forms derived from that same building mass will only convey the same, or perhaps even more, acceptance from the existing community. Additionally, this breaking of the form immediately begins to increase density within neighborhoods by inherently offering more livable spaces and offers more logical designs toward the changing demographics of city residential areas.

Large or double lot with small older home is purchased

TYPICAL DEVELOPMENT

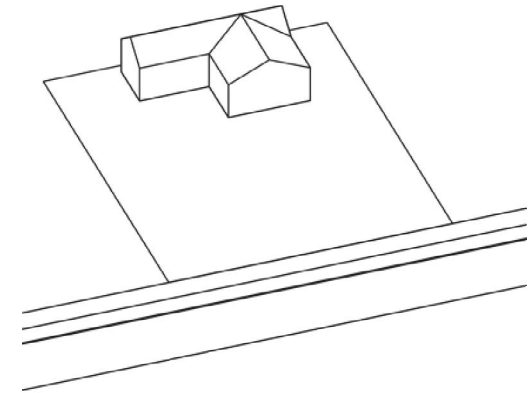

Large or double lot with small older home is purchased paying attention to zoning and possibilities toward increased density

ALTERNATIVE DEVELOPMENT

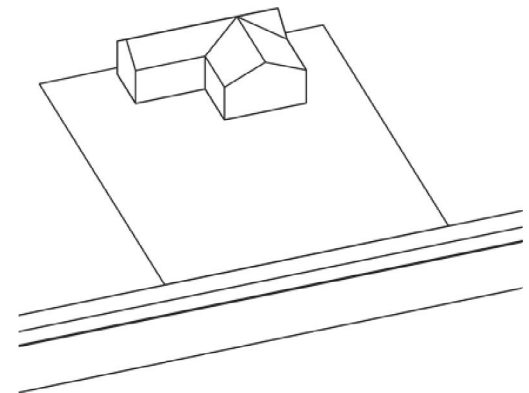

Existing home is demolished

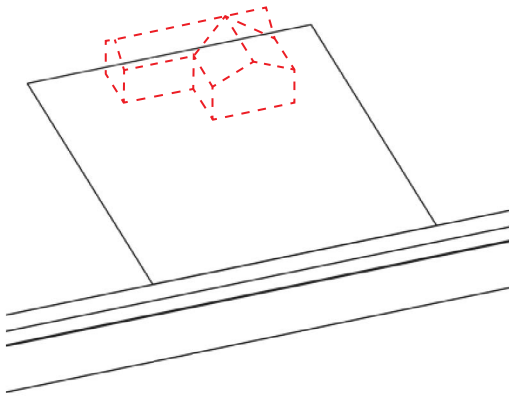

New large home is built as large as possible to maximize profit

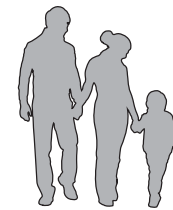
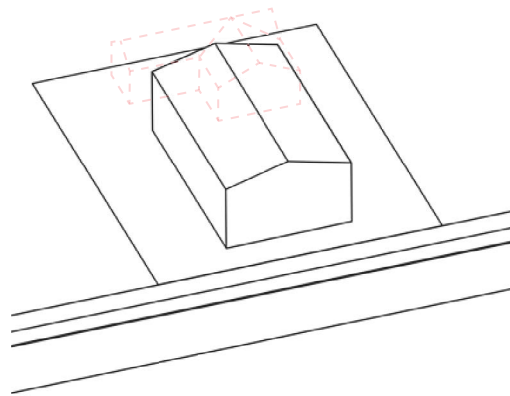

Average Occupancy

2-4

Existing home is remodeled and large home form is split to facilitate multiple smaller units

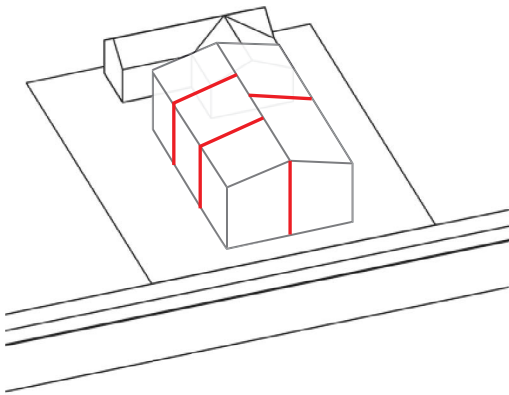

Micro-housing community is created with multiple units providing higher density within roughly the same footprint of large home in typical development

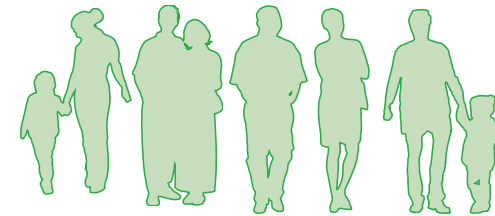
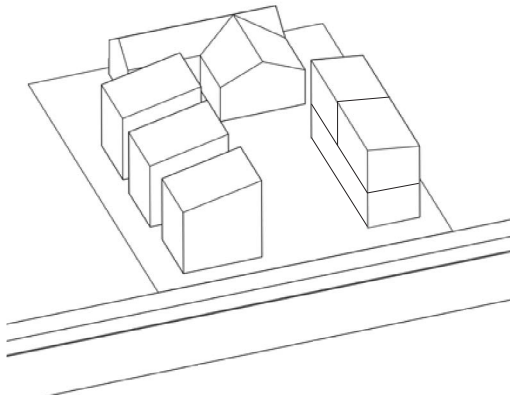

Average Occupancy

6-8

Figure 4.4 - Building Form Diagram

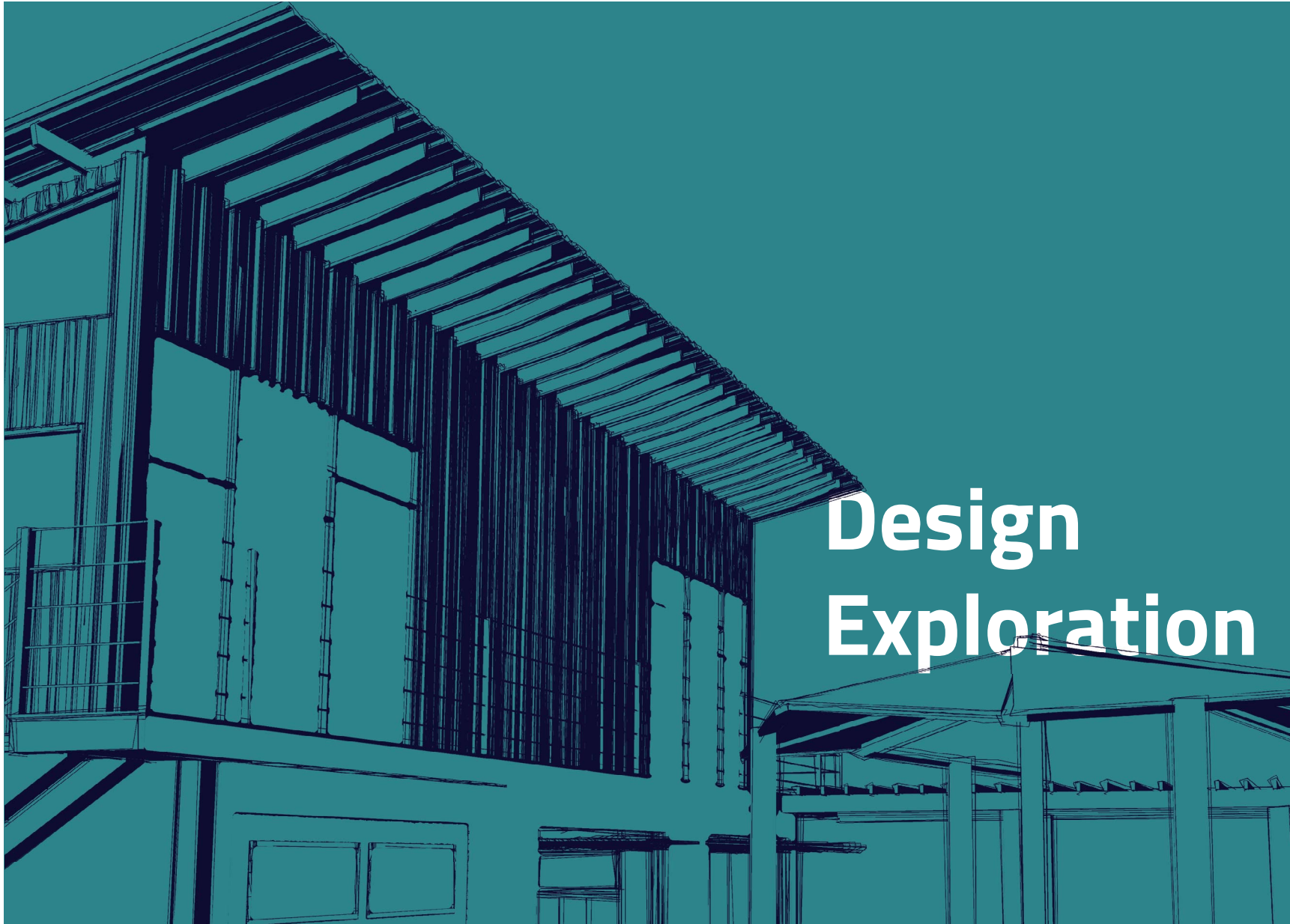

Design Exploration

Creating a Micro-Housing Community

There are many methods to designing space for small residential living from traditional small Japanese homes built throughout centuries past, to the more recent tiny house and small house movements, and cottage neighborhood developments. However, while this design strives to incorporate inspiration from a variety of those methods, the overall focus is how the space – both indoor and outdoor – can be best utilized within an alternative development system meant for providing homes and communities to lower income individuals who may otherwise be displaced or excluded from dwelling within the urban neighborhood landscape. This design seeks to answer questions of how individuals would utilize a micro-housing community to best suit the needs of their lifestyles which do not fit within the typical mother, father, and two children paradigm.

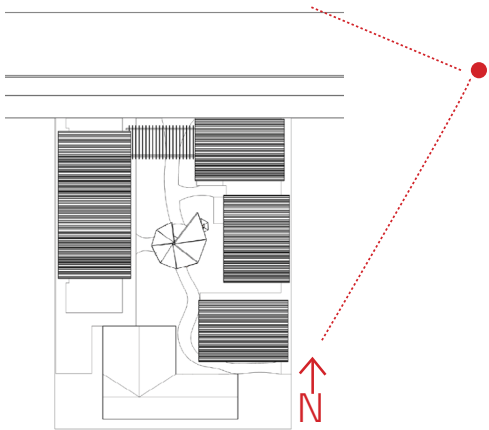

Perspective 01

This view provides a sense of context of the proposed micro-housing community within the neighborhood. Although the overall design is spread out more than the typical large house that would be constructed following current development trends, it retains similar aesthetics in regards to the massing shape and heights of the buildings.



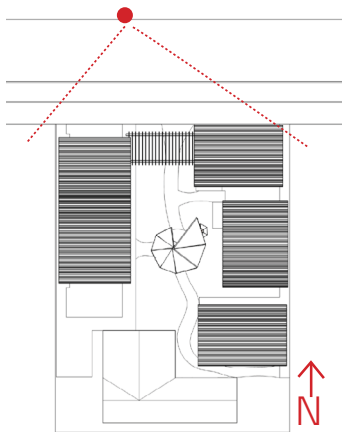

Perspective 02

This perspective showing the street side of the development begins to give a sense of how the trellis, inner courtyard space, and community center all formalize the process of transition from the larger neighborhood fabric into the shared and open spaces offered by the micro-community. The walkways on the perimeter of the site designate a more private route which may be chosen by residents seeking a more private entrance and easier access to the dwellings as well as bike parking and private gardens.



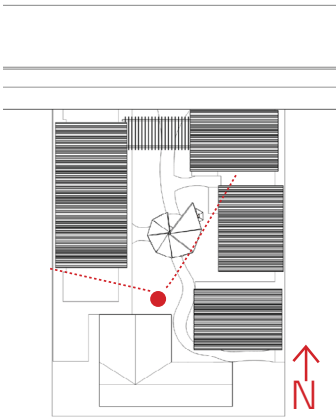

Perspective 03

Looking out from the courtyard shows the connectivity between the living and community spaces as well as the interactions between residents and the overall community within the shared common spaces, vegetable gardens, and artist workshop and gallery.



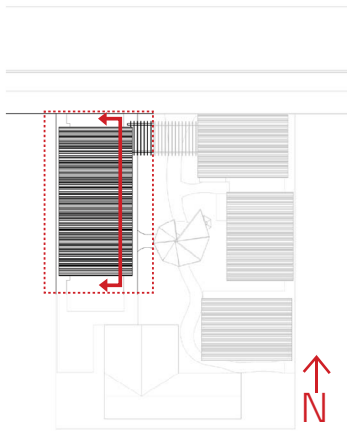

Section Perspective 01

This section diagram tells the story of how the smallest units on the site – Unit Type C – interact with the artist workshop and gallery located in the space below. Residents of the units can easily access the workshop space to explore their own projects as well as provide community education and utilize the gallery space to present their own works and/or works from other artists living in micro-community sister sites or even the neighborhood as a whole.



Unit Type C
300sf

Unit Type C
300sf

Bedroom
90sf

W/C
50sf

W/C
50sf

Bedroom
90sf

Kitchen / Dining Area
90sf

Kitchen / Dining Area
90sf

Living Room
70sf

Living Room
70sf

Artist Workshop
275sf

W/C
50sf

Artist Gallery
275sf

Community Space
600sf

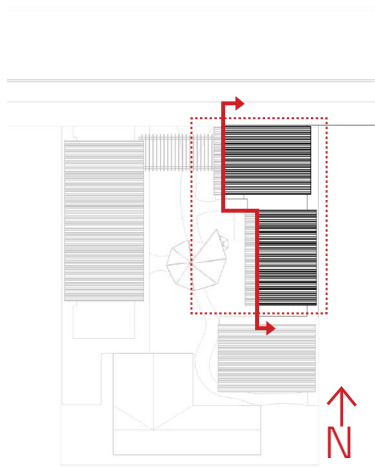

Section Perspective 02

This diagram shows how the two slightly different 600 square foot units – types A and B – would be utilized by the residents. Type A provides an additional sleeping space in a loft area above the bedroom which would ideally be utilized by children within a single parent or even small family household. Type B would be best suited for a single person, or couple – young or elderly – who is interested in playing a strong role in maintaining and promoting micro-community developments.



Loft
80sf

Bedroom
230sf

W/C
50sf

Kitchen / Dining Area
125sf

Storage
25sf

Living Room
150sf

Unit Type A
660sf

Bedroom
230sf

W/C
50sf

Balcony

Storage
25sf

Living Room
150sf

Kitchen / Dining Area
125sf

Unit Type B
600sf

Private
Garden

Private
Garden

Ground Level Floor Plan

This drawing begins to show circulation through the site and access – both private and public – to the varying unit types, as well as the layout of the ground floors of the units. The existing house in this case has been rehabbed in order to be used as another residential unit. Several gardens are meant for community use and access as well the central gazebo and surrounding landscaped areas, while several private outdoor patios and gardens are meant to only be utilized by the residents within the respective units.

SE Raymond St



Scale : 3/32" = 1'



SE Raymond St



Second Floor Plan

Scale : 3/32" = 1'



Resident Profile:
 Typical Day for Single Mother and Daughter
 Living in 600sf Unit



7:00am

Wakes up/makes breakfast/heads to class at community college/drops daughter at day care

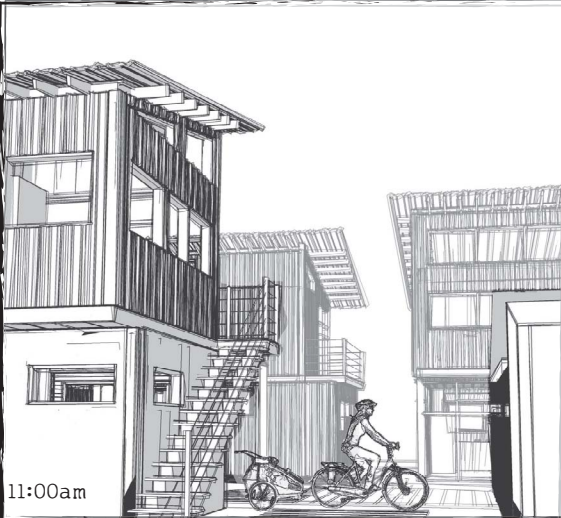

11:00am

Comes home from class/locks up bike in bike shed

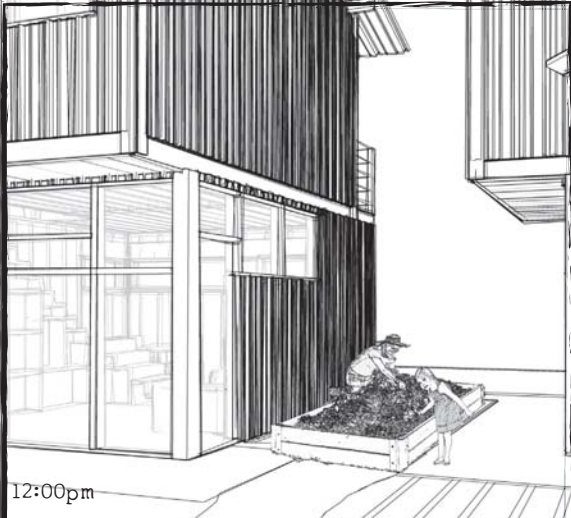

12:00pm

Makes lunch/works on garden/plays in courtyard



2:00pm

Watches neighbors son after he gets home from school



4:00pm

Drops off daughter with neighbor/goes to work

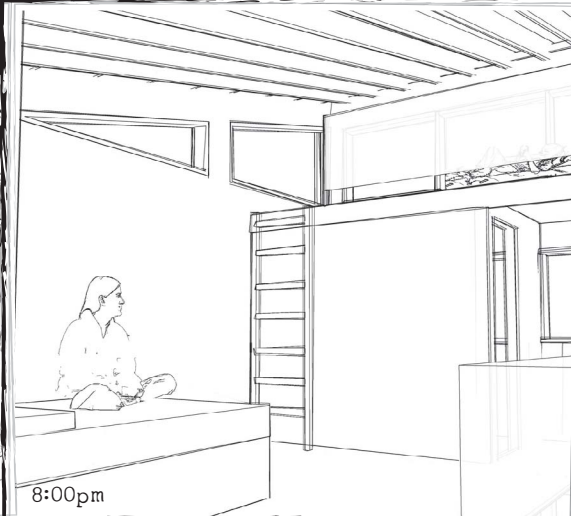

8:00pm

Picks up daughter from neighbor/gets ready for bed

Figure 5.8 - Day in the Life Diagram, Single Mother

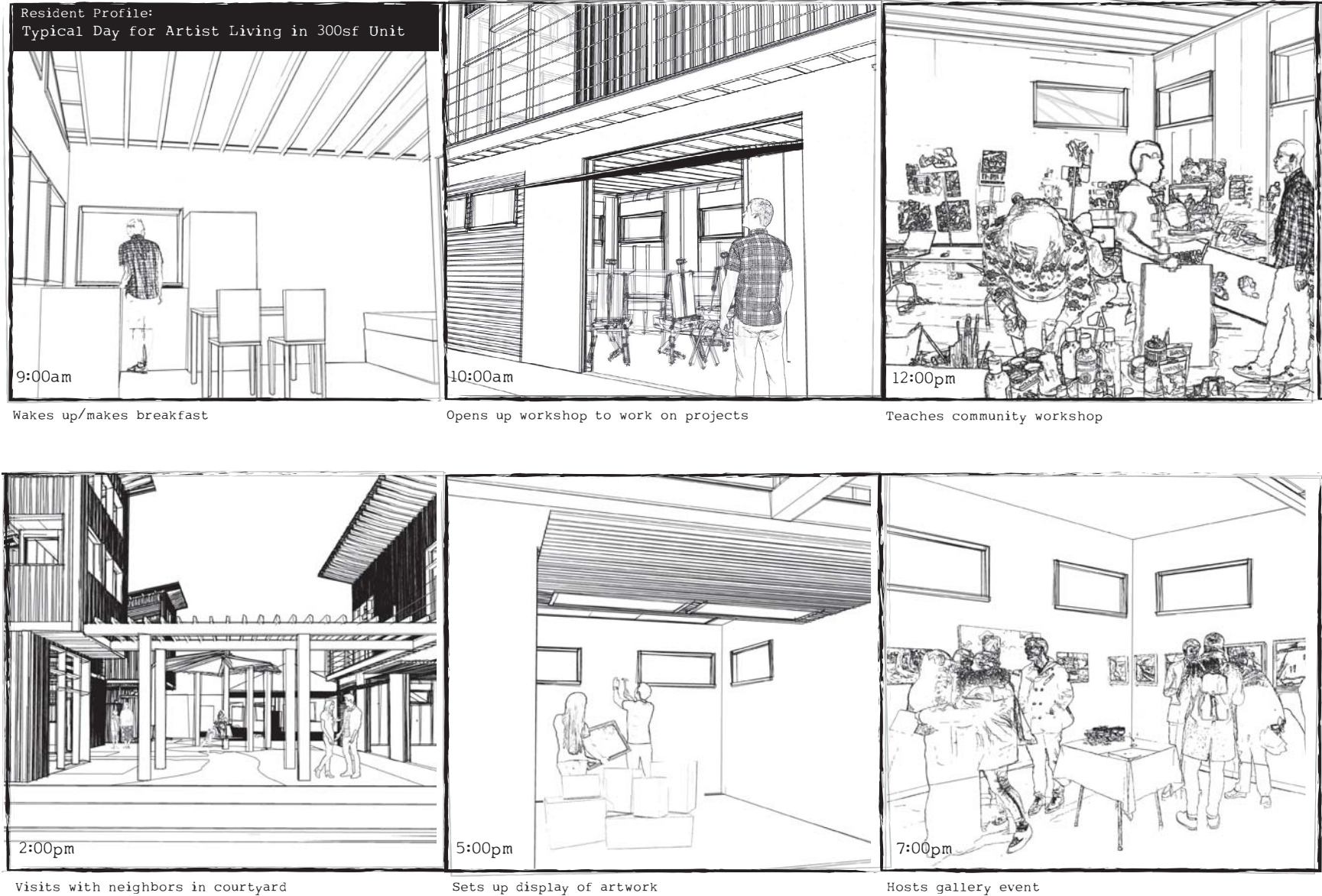

Figure 5.9 - Day in the Life Diagram, Artist



Conclusion

Next Steps Toward Integrating Micro-Housing Communities

While the concept presented here is the start of a clear path toward urban neighborhoods maintaining affordability, and community development through an alternative housing development model, it only begins to assemble notions and knowledge toward successfully integrating a micro-housing community project into the neighborhood fabric. As much as a well-designed space would begin to make people notice the possibilities and potential of sites like these, the larger challenge is to present a clear methodology to every party involved in making a proposal along these lines into a reality, including the developer, banking institutions, non-profit organizations, prospective residents, city officials, and the existing community. The proposed methodology presented here only opens the door and would need to incorporate much more finite details exploring a deep understanding of financing, funding, construction feasibility, neighborhood demographics, community willingness and need, and projected impacts – both positive and negative. However, it has been made evident through numerous interviews with local developers and non-profit organizations that either this or some form of alternative residential development plan would be tremendously beneficial within the current housing climate and demographic shifts taking place within urban neighborhoods; therefore, it is only a matter of creating and presenting the most refined system and proposal to begin a movement toward a new form of housing that specifically reacts to recent trends rather than proliferating the myth of desiring an oversized single family home which has become so pervasive – and unnecessary – within the urban neighborhood fabric.

Development Update of Proposed Sites

As expected each existing residence at the sites chosen within the neighborhood and design study presented within this proposal has been demolished. Two of those three sites have ongoing residential constructions which, not surprisingly, consist of the typical large 3000+ square foot single family homes.



3815 SE 70TH AVE



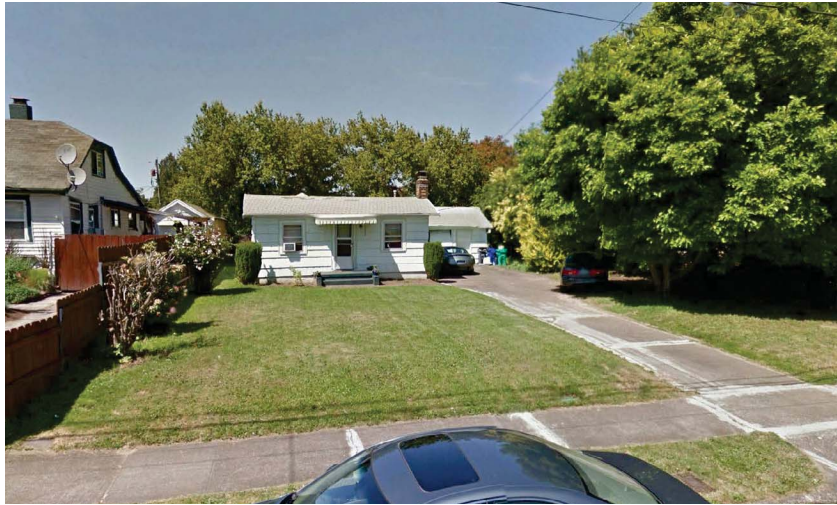

8035 SE CENTER ST



7932 SE RAYMOND ST



Figure 6.1 - Previous and Current Site Conditions

List of Figures

Figure 0.1 - Relocation Diagram. Photos and Map by Author.

Figure 0.2 - Before and After Comparison of Homes within the Foster Powell Neighborhood. *Photo source: Google Maps.*

Figure 1.1 - Diagram of Portland Housing Landscape. *Graphics by Author.*

Figure 1.2 - Population Growth vs. Housing Growth Chart. *Data Source: U.S. Census Bureau. Graphics by Author.*

Figure 1.3 - Housing Affordability Chart. *Map and Data Source: Portland Housing Bureau 2015 State of Housing Report. Graphics by Author.*

Figure 1.4 - Housing Income Affordability Chart. *Data Source: hsh.com and Sentier Research. Graphics by Author.*

Figure 1.5 - Rental Vacancy Rate Comparison Chart. *Data Source: U.S. Census. Graphics by Author.*

Figure 1.6 - Portland Residential Demolitions (2015) Chart. *Data Source: Portland Chronicle. Graphics by Author.*

Figure 2.1 - For Profit Development Model. *Graphics by Author.*

Figure 2.2 - Alternative For Profit Development Model. *Photo Sources: Google Earth and Oregon Live. Graphics by Author.*

Figure 2.3 - Alternative Non-Profit Development Model. *Proud Ground Logo Source: proudground.com. Graphics by Author.*

Figure 2.4 - Existing Local Micro-Communities. *Graphics by Author.*

Figure 2.5 - Pocket Neighborhood Typologies. *Graphics by Author.*

Figure 2.6 - Tiny House Village Typologies. *Graphics by Author.*

Figure 2.7 - Middle Housing Typologies. *Graphics by Author.*

Figure 3.1 - Site Investigations. *Graphics by Author. Photo Source: Google Maps.*

Figure 3.2 - Foster Powell Neighborhood Demographics. *Data Source: U.S. Census Bureau and Portland Housing Bureau. Graphics by Author.*

Figure 3.3 - Initial Design Investigations. *Graphics by Author.*

Figure 4.1 - Micro-Housing Community Development Proposal. *Photos and Graphics by Author.*

Figure 4.2 - Cost Analysis Diagram. *Graphics by Author.*

Figure 4.3 - Community Connection Diagram. *Graphics by Author.*

Figure 4.4 - Building Form Diagram. *Graphics by Author.*

Figure 5.1 - Perspective 01. *Graphics by Author.*

Figure 5.2 - Perspective 02. *Graphics by Author.*

Figure 5.3 - Perspective 03. *Graphics by Author.*

Figure 5.4 - Section Perspective 01. *Graphics by Author.*

Figure 5.5 - Section Perspective 02. *Graphics by Author.*

Figure 5.6 - Ground Level Floor Plan. *Graphics by Author.*

Figure 5.7 - Second Level Floor Plan. *Graphics by Author.*

Figure 5.8 - Day in the Life Diagram, Single Mother. *Graphics by Author.*

Figure 5.9 - Day in the Life Diagram, Artist. *Graphics by Author.*

Figure 6.1 - Previous and Current Site Conditions. *Photo Source: Google Maps and Author.*

Bibliography

- Barton, Hugh. "The Neighbourhood as Ecosystem." In *Sustainable Communities*, 87-104. London, UK: Earthscan Publications, 2000.
- Bor, Walter. "A Fresh Approach to High Density Housing." *Official Architecture and Planning*, 1962.
- Brown, Neave. "The Form of Housing." *Architectural Design* 37 (1967): 432-33.
- Brown, Azby. *The Very Small Home: Japanese Ideas for Living Well in Limited Space*. Tokyo: Kodansha International, 2005.
- Charley, Jonathan. "The Glimmer of Other Worlds: Questions on Alternative Architectural Practice." *Architectural Research Quarterly* 12, no. 2 (2008): 159-71.
- Chapin, Ross. *Pocket Neighborhoods: Creating Small-scale Community in a Large-scale World*. Newtown, CT: Taunton Press, 2011
- Chaskin, Robert J., and Mark L. Joseph. "'Positive' Gentrification, Social Control and the 'Right to the City' in Mixed-Income Communities: Uses and Expectations of Space and Place." *Int J Urban Reg Res International Journal of Urban and Regional Research*, 2012, 480-502.
- Heben, Andrew. "Inside tent cities: a few places allow them; others continue to push them around." *Planning* 77, no. 8 (October 2011): 23-25. Avery Index to Architectural Periodicals, EBSCOhost (accessed October 6, 2015).
- Heller, Allison, and Toby Adams. "Creating healthy cities through socially sustainable placemaking." *Australian Planner* 46, no. 2 (June 2009): 18-21. Avery Index to Architectural Periodicals, EBSCOhost (accessed October 21, 2015).
- Harper, Caleb Benjamin. "Vertical Village: Towards a New Typology of High-Density Low-Income Incremental Housing" MS diss., Massachusetts Institute of Technology, 2014.
- Isenberg, Jay. "Unbundling the housing crisis." *Oz / College Of Architecture & Design Kansas State University* 32, (2010): 17-25. Avery Index to Architectural Periodicals, EBSCOhost (accessed October 7, 2015).
- Jacobs, Jane. *The Death and Life of Great American Cities*. New York: Random House, 1961. 1-54.
- Jun, Myung-Jin. "The effects of Portland's urban growth boundary on housing prices." *Journal Of The American Planning Association* 72, no. 2 (Spring 2006): 239-243. Avery Index to Architectural Periodicals, EBSCOhost (accessed October 7, 2015).
- Mirviss, Laura. 2014. "Portland: Oregon's largest city embraces high-density living." *Architectural Record* 202, no. 10: 116-121. Avery Index to Architectural Periodicals, EBSCOhost (accessed October 7, 2015).
- Manning, Jeff. "Working Class priced Out, Kicked out in New Portland Housing Boom." *OregonLive*. September 22, 2015. Accessed November 2, 2015.

Mesh, Aaron. "Portland's Rent Spike Spreads East, Pressuring Low-Income Residents." *Willamette Week*. October 1, 2015. Accessed November 5, 2015.

Portland Housing Bureau. *State of Housing in Portland* October 2015. City of Portland. September 2015. Accessed December 2015. <https://www.portlandoregon.gov>.

Spevak, Eli. "Plank of Progressive Planning Ideas for Portland That Won't Piss Off the Neighbors." *Orange Splot*. June 6, 2015. Accessed October 21, 2015.

Streckert, Joe. "How We Got Here." *Portland Mercury*. August 5, 2015. Accessed October 28, 2015.

Swenarton, Mark. "Developing a new format for urban housing: Neave Brown and the design of Camden's Fleet Road estate." *Journal Of Architecture* 17, no. 6 (December 2012): 973-1007. Avery Index to Architectural Periodicals, EBSCOhost (accessed October 22, 2015).

Theen, Andrew. "Tiny Houses for Homeless People? Portland Mayor Charlie Hales Is 'infatuated' with the Idea, Advisor Says." Accessed October 8, 2015.

Van Gieson, John. "Mid-Range Density." *Realtor.org*. December 6, 2013. Accessed October 29, 2015.